



# RACE BARRIER BOPLAN SPORT SPECIFICATION SHEET

Revision: 3 August 2021 9:03 AM



## PRODUCT SPECIFICATIONS

### APPLICATION

Environment	Designed for sporting events - such as cycling races - with risk of collision of participants with spectators and obstacles. Outdoor and indoor use
Features	1,4 meter tall and angled for separation of participants and spectators Safety yellow for maximum visibility Air cushion for controlled impact absorption and impact deflection Rounded shape with soft polymer to minimize injuries in the event of a crash Quick and easy installation Foldable for efficient storage and transportation Can be filled with water for increased stability Can be weighted with optional boards with sandbags Use of UV proof polymer
Crash impact	Intended to deflect and absorb the energy from impact Not intended for vehicle impact

### MATERIAL

Barrier and legs	TPE polymer
------------------	-------------

### STANDARD COLORS

Barrier	Yellow RAL 1003
Legs	Black RAL 9005





## FEATURES AND FUNCTIONALITY

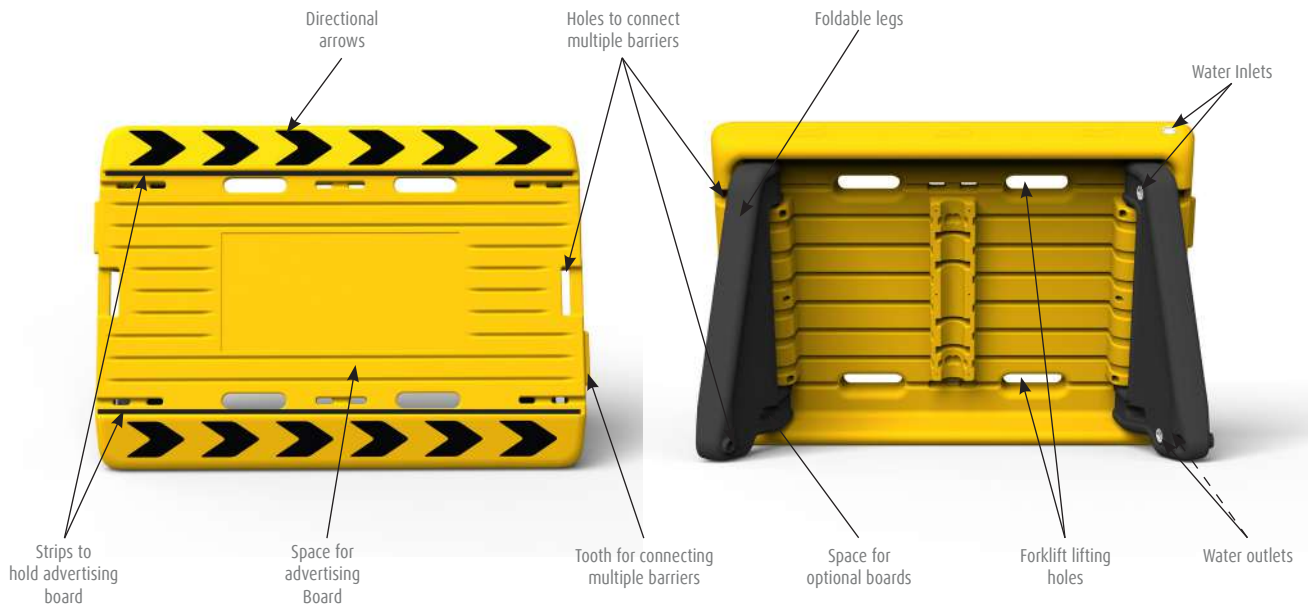

Weight: 40 kg

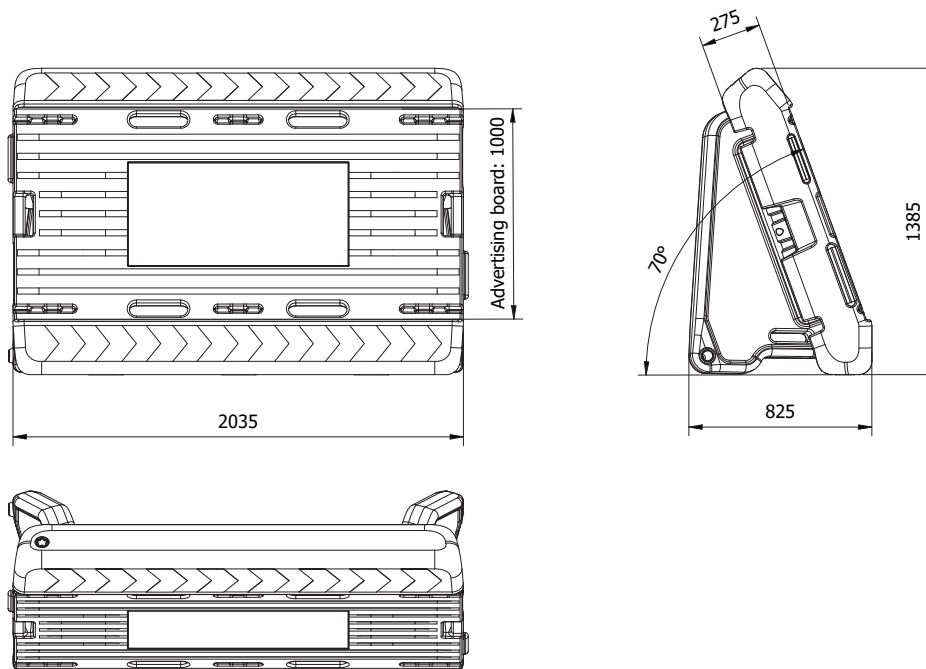



## FEATURES AND FUNCTIONALITY

Connecting multiple barriers

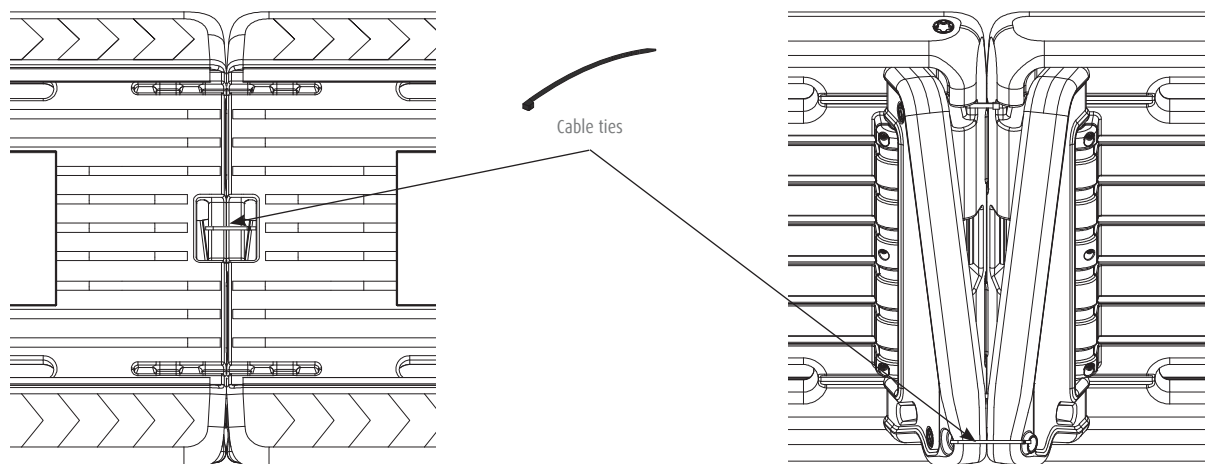

Foldable legs that snap in place

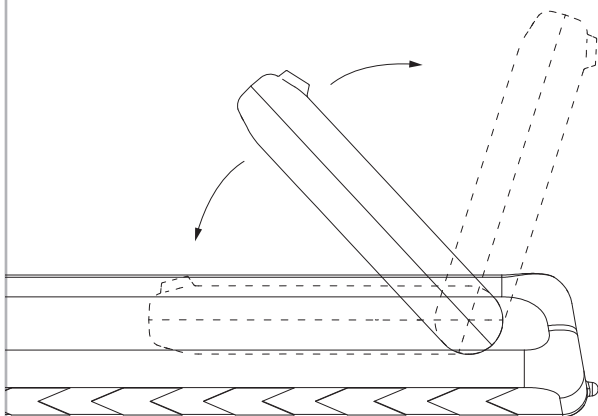

Carry by forklift

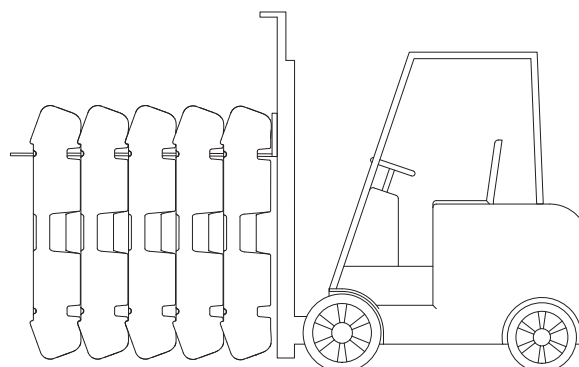



#### REFERENCE LIST - RACE BARRIER

SPRB-1385-2035-SETYB	Race Barrier SET - YE body / BL leg	
----------------------	--	---

#### REFERENCE LIST - RACE BARRIER - SPARE PARTS

SPRB-1385-2035-BOYE	Race Barrier Body - YE	
SPRB-1385-2035-CAP	Race Barrier Cap - BCS 56x4 - WH	
SPRB-1385-2035-COBL	Race Barrier Cover - BL	
SPRB-1385-2035-LEBL	Race Barrier Leg - BL	



(c) Flanders classics