



OLMO

collezione 2024



IT. Giuseppe Olmo, detto Gepin è stato uno dei protagonisti assoluti del ciclismo italiano su strada sia al Giro che nelle Classiche dell'epoca. Il 31 ottobre 1935 entra nella leggenda demolendo il record dell'ora su pista del francese Richard e stabilendo il primato di 45.090 km percorsi. Nel 1939 Giuseppe fonda la Olmo Biciclette: in pochi anni dalla fabbrica di Celle Ligure escono le biciclette da competizione più performanti e tecnicamente avanzate del periodo, testate direttamente da Gepin e pronte per essere portate in trionfo dai ciclisti professionisti.

EN. Giuseppe Olmo, known as Gepin, was one of the top road racers in Italian cycling, both in the Giro d'Italia and in the Classics races of the time. On October 31, 1935, Gepin became a legend by demolishing the hour track record held by the French cyclist Richard and establishing the new record of 45.090 km. In 1939 Giuseppe founded Olmo Biciclette: in just a few years the Celle Ligure factory produced the highest performing and technically most advanced racing bicycles of the time, tested directly by Gepin and ready to be ridden in triumph by professional cyclists.

FR. Giuseppe Olmo, dit Gepin, est l'un des protagonistes absolus du cyclisme italien sur route, que ce soit au Tour d'Italie ou dans les Classiques de l'époque. Le 31 octobre 1935, il entre dans la légende, anéantissant le record de l'heure sur piste du Français Richard et établissant le record de 45.090 km parcourus. En 1939, Giuseppe fonde l'entreprise Olmo Biciclette: en quelques années, l'usine de Celle Ligure produit les vélos de compétition les plus performants et techniquement avancés de l'époque, directement testés par Gepin et prêts pour être portés en triomphe par les cyclistes professionnels.

ES. Giuseppe Olmo, apodado Gepin, fue uno de los protagonistas absolutos del ciclismo italiano de carretera, tanto en el Giro como en las clásicas de la época. El 31 de octubre de 1935 pasa a formar parte de la leyenda, pulverizando el récord de la hora en pista del francés Richard y estableciendo el récord de 45.090 Km recorridos. En 1939 Giuseppe funda Olmo Biciclette: en pocos años, de la fábrica de Celle Ligure salen las bicicletas de competición con más prestaciones y técnicamente más avanzadas de la época, comprobadas directamente por Gepin y listas para triunfar al lado de ciclistas profesionales.

GIUSEPPE "GEPIN" OLMO, THE CHAMPION



■ **1932**
Los Angeles Olympic Games

■ **1938**
Milano-Sanremo

■ **1934 — 36**
Twenty stage victories at Giro d'Italia

■ **1935**
Milano-Sanremo the hour Record

■ **1978**
Zonca Santini Olmo
IT. Nel 1978 Pierino Gavazzi si aggiudica il campionato italiano su strada con il team Zonca-Santini-Olmo e la Milano-Sanremo del 1980 tra le fila della Magniflex-Olmo.

EN. In 1978 Pierino Gavazzi won the Italian road championship with the Zonca-Santini-Olmo team and the 1980 Milan-San Remo with Magniflex-Olmo.

FR. En 1978, Pierino Gavazzi s'adjuge le championnat italien sur route, avec le team Zonca-Santini-Olmo, et la Milan-Sanremo de 1980 dans les rangs de Magniflex-Olmo.

ES. En 1978 Pierino Gavazzi se adjudica el campeonato italiano en carretera con el equipo Zonca-Santini-Olmo y la Milan-San Remo de 1980 en las filas del Magniflex-Olmo.

■ **1980 — 81**
Magniflex Olmo

■ **1982**
Gis Gelati Olmo

■ **1983 — 84**
Alfa Lum Olmo

■ **1998 — 00**
Vitalicio Seguros
IT. Dal 1998 al 2000 il team Vitalicio Seguros si afferma in tre campionati spagnoli e nel campionato del mondo di ciclismo su strada a Verona, nel 1999, con Oscar Freire.

EN. From 1998 to 2000 the Vitalicio Seguros team, with Oscar Freire, made a name for itself in three Spanish championships and in the world road cycling championship in Verona in 1999.

FR. De 1998 à 2000, le team Vitalicio Seguros s'affirme dans trois championnats espagnols et dans le championnat du monde de cyclisme sur route à Vérone, en 1999, avec Oscar Freire.

ES. De 1998 a 2000 el equipo Vitalicio Seguros se afianza en tres campeonatos españoles y en el campeonato del mundo de ciclismo en carretera de Verona, en 1999, con Óscar Freire.

■ **2001**
Cantina Tollo, Acqua & Sapone

■ **2002**
Cage Maglierie Olmo

■ **2003 — 05**
Tenax Menikini

■ **2013 — 19**
Andrea Secchiero, Fiamme Oro

■ **2017 — 19**
Sangemini, Mg.K Vis

■ **2020**
Sangemini, Trevigiani, Mg.K Vis, Vpn Cycling Team

■ **2021**
Mg.K vis, Vpn Cycling Team / Northware Siatek Olmo / Gragnano sporting club

■ **2022 — 23**
Mg.Kvis, Color for peace, Vpn / So.L.Me Olmo / Gragnano Sporting Club



Los Angeles Olympic Games

Twenty stage victories at Giro d'Italia

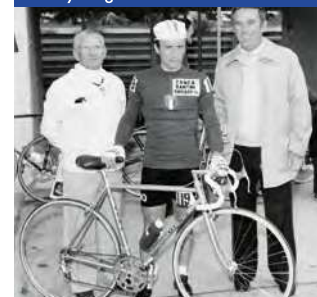

Magniflex Olmo

Alfa Lum Olmo



Gis Gelati Olmo



2020



Andrea Secchiero



2022



2023



RACING ATTITUDE



IT. Il legame tra Olmo e le competizioni affonda le radici nelle imprese sportive di Giuseppe Olmo, detto Gepin, protagonista tra il 1932 e il 1938 di prestazioni che hanno reso grande il ciclismo italiano. Dal 1939, anno della fondazione della Olmo biciclette, i modelli di punta hanno equipaggiato decine di team e professionisti di tutto il mondo.

FR. Le lien entre Olmo et les compétitions remonte aux entreprises sportives de Giuseppe Olmo, dit Gepin, protagoniste, entre 1932 et 1938, de prestations qui ont contribué à faire du cyclisme italien le grand sport qu'il est aujourd'hui. À partir de 1939, année de la fondation de l'entreprise Olmo Bicyclette, les modèles de pointe ont équipé des dizaines de teams et de professionnels du monde entier.



EN. The connection between Olmo and racing has its roots in the sporting achievements of Giuseppe Olmo, better known as Gepin, the racer whose performances from 1932 to 1938 helped make Italian cycling great. Since 1939, when Olmo bicycles was founded, our top models have equipped dozens of teams and have been ridden by professionals from all over the world.

ES. La relación entre Olmo y el mundo de la competición tiene sus raíces en las gestas deportivas de Giuseppe Olmo, apodado Gepin, que entre 1932 y 1938 protagonizó unas prestaciones que contribuyeron a la grandeza del ciclismo italiano. A partir de 1939, año en que se fundó Olmo Bicyclette, sus modelos punteros han equipado a decenas de equipos y profesionales del mundo entero.

NORTHWAVE - SIATEK - OLMO





76° TROFEO VISENTINI - So.L.Me Olmo

KTK KALISZ - Jakub Gilicki - Poland 2023



INDEX

07 CORSA

08	Nerax
14	Gepin 4.0
18	Gepin
22	911TT Triathlon / TE Crono
24	Zerodieci
26	Zerocinque
30	Bormida
33	X-Trada

48 E-BIKE

52	E-Bro 2.0
56	E-Grit
60	Slalom
66	Rapida 2.0
68	E-Kolt
76	E-Vag 29"
78	Thuras 29"
80	E-Jet 24"
82	E-Xcursion
84	Vico Trk
86	Vico City
90	Naviglio
96	Levante 28"/26"
102	Pixel

142 APPAREL

142	Corsa Nero
143	Corsa Blu

36 MTB

38	Bignone
40	Hetna
42	Carmo
44	Turchino 29"
46	Giovi 27,5"

103 QUOTIDIANE

104	Nava
108	Demonte 27,5"/24"/20"
112	Sentiero 26"/24"/20"
116	Avventura 26"/24"/20"
120	Graffito 20"
122	Borgo
128	Bivio
130	Anita 28"/26"
132	Alya 20"/24"
134	Popz 16"/12"
135	Flor 16"/12"
136	Darsena
139	Centro
140	Sport

CORSA

The racing machine



NERAX



IT. La punta di diamante della produzione Olmo è la NERAX, sinonimo di leggerezza e integrazione. Tutto ciò che i ciclisti più perfezionisti cercano nelle biciclette più evolute: leggerezza, controllo in velocità, rendimento in frenata, stabilità, trasmissione elettronica, aerodinamicità e integrazione totale dei cavi. La particolarità della Olmo Nerax è il tipo di carbonio utilizzato nella sua costruzione: T24 al 45% - T30 al 45% e T36 al 10%. Grazie a questo il telaio raggiunge lo straordinario peso di 750 gr (+/- 5-6% grezzo) nella misura piccola fino agli 850 gr (+/- 5-6% grezzo) nella misura più grande diventando così più leggero ma allo stesso tempo più rigido e performante.

FR. Le haut de gamme de la production Olmo est le NERAX, synonyme de légèreté et d'intégration. Tout ce que les cyclistes les plus perfectionnistes recherchent dans les vélos les plus performants : légèreté, contrôle, performance du freinage, stabilité, transmission électronique, aérodynamisme et intégration totale des câbles. La particularité d'Olmo Nerax est le type de carbone utilisé dans sa construction : T24 à 45% - T30 à 45% et T36 à 10%. Grâce à cela, le cadre atteint le poids extraordinaire de 750 gr (+/- 5-6% brut) dans la plus petite taille jusqu'à 850 gr (+/- 5-6% brut) dans la plus grande devenant ainsi plus léger mais en même temps plus rigide et performant.

EN. NERAX is the absolute gem of OLMO production, a perfect combination of lightness and integration.

Nerax has everything a perfectionist cyclist is looking for: lightness, high-speed road holding, highly efficient braking, stability, electronic drive unit, aerodynamics and wholly-integrated cables.

The peculiarity of Olmo Nerax is the type of carbon employed for its production: 45% of T24 - 45% of T30 and 10% of T36. The result is a more rigid and performing frame with an extraordinary weight of 750 gr (+/- 5-6% raw) in its small size and 850 gr (+/- 5-6% raw) in its larger size.

ES. La punta de lanza de la producción de Olmo es la NERAX, sinónimo de ligereza e integración. Todo lo que los ciclistas más perfeccionistas buscan en las bicicletas más avanzadas: ligereza, control de velocidad, rendimiento de frenada, estabilidad, transmisión electrónica, aerodinámica e integración total de los cables.

La peculiaridad de Olmo Nerax es el tipo de carbono utilizado en su construcción: T24 al 45% - T30 al 45% y T36 al 10%. Gracias a esto el cuadro alcanza el extraordinario peso de 750 gr (+/- 5-6% crudo) en la medida pequeña hasta 850 gr (+/- 5-6% crudo) en la medida más grande volviéndose así más ligero pero al mismo tiempo más rigido y eficaz.

NERAX

VO0805 / Campagnolo Super Record WRL 2x12



COLORS



COLOR CONFIGURATOR



PESO
WEIGHT
PESO
POIDS

7 kg h.49

COLORE IN FOTO
COLOR IN PICTURE

NERO-ORO C917

NERAX

VO0810-13 / Shimano Dura Ace Di2 2x12 + Manubrio Alanera e ruote Vision Carbon



COLORS



COLOR CONFIGURATOR



COLORE IN FOTO
COLOR IN PICTURE

ROSSO METALLIZZATO C018

PESO
WEIGHT
PESO
POIDS

6,9 kg h.51

NERAX

VO0820-4 / Shimano Ultegra Di2 2x12 + Ruote Vision Carbon 55



COLORS



COLOR CONFIGURATOR



PESO
WEIGHT
PESO
POIDS

7,5 kg h.53

COLORE IN FOTO
COLOR IN PICTURE

TURCHESE C019

NERAX

VO0834 / Shimano 105 Di2 2x12



COLORS



COLOR CONFIGURATOR



COLORE IN FOTO
COLOR IN PICTURE

BIANCO-MAGENTA C302

PESO
WEIGHT
PESO
POIDS

8,1 kg h.49

NERAX

	TELAIO FRAME CADRE CUADRO	FORCELLA FORK FOURCHE HORQUILLA	CAMBIO GEARS CAMBIO POST. ARRIER DER.	DERAGL. DERAILLEUR CAMBIO ANT. AVANT DER.	COMANDI CONTROLS PALANCAS DE CAMBIO MANETTES	GUARN. CRANKSET BIELA PEDALIER	CASSETTA CASSETTE CASSETTE CASSETTE	FRENI BRAKES FRENOS FREINS	MANUBRIO HANDLEBAR MANILLAR GUIDON	RUOTE WHEELS RUEDAS ROUES	GOMME TYRES PNEUMATICOS PNEUS	SELLA SADDLE SELLE SILLIN	REGGISSELLA SEAT POST TIGE DE SELLE TIJA
VO0805 Campagnolo Super Record WRL 2x12	Road Carbon monocoque "Nerax" Ultralight	Carbon monocoque "Nerax"	Campagnolo Super Record WRL	Campagnolo Super Record WRL	Campagnolo Super Record WRL	Campagnolo SR ProT Carbon 34-50	Campagnolo Super Record 10-29	Campagnolo Super Record	Deda Alanera	Campagnolo Bora Ultra WTO 45	Vittoria Corsa N.EXT 700x28 TLR Tubeless	Selle Italia SLR Boost TI	Carbon
VO0810 Dura Ace Di2 2x12	Road Carbon monocoque "Nerax" Ultralight	Carbon monocoque "Nerax"	Dura Ace 9250	Dura Ace 9250F	Dura Ace 9270	Dura Ace 9200 50-34	Dura Ace 9200 11-34	Dura Ace 9270	Deda Superbox / Deda Zerocento	Mavic Ksyrium 30 D	Vittoria Corsa N.EXT 700x28 TLR Tubeless	Selle Italia SLR Boost TI	Carbon
VO0820 Ultegra Di2 2x12	Road Carbon monocoque "Nerax" Ultralight	Carbon monocoque "Nerax"	Ultegra 8150	Ultegra 8150F	Ultegra 8170	Ultegra 8100 50-34	Ultegra 8100 11-34	Ultegra 8170	Deda Superbox / Deda Zerocento	Mavic Ksyrium 30 D	Vittoria Rubino PRO 700x28 TLR Tubeless	Selle Italia SLR Boost TI	Carbon
VO0834 Shimano 105 Di2 2x12	Road Carbon monocoque "Nerax" Ultralight	Carbon monocoque "Nerax"	Shimano 105 7150	Shimano 105 7150F	Shimano 105 7170	Shimano 105 7100 50-34	Shimano 105 7100 11-34	Shimano 105 7170	Deda Superbox / Deda Zerocento	Mavic Ksyrium 30 D	Vittoria Rubino PRO 700x28 TLR Tubeless	Selle Italia SLR Boost TI	Carbon
VO0832 Shimano 105 2x12	Road Carbon monocoque "Nerax" Ultralight	Carbon monocoque "Nerax"	Shimano 105 7100	Shimano 105 7100F	Shimano 105 7120	Shimano 105 7100 50-34	Shimano 105 7100 11-34	Shimano 105 7120	Deda Superbox / Deda Zerocento	Fulcrum R900 DB / Mavic Aksium	Vittoria Rubino Pro 700x25 Speed	Selle Italia SLR Boost TI	Carbon

COLORS

ROSSO METALLIZZATO C018

TURCHESE C019

CHOOSE
YOUR
COLORS



COLOR CONFIGURATOR

OPTIONAL

VO0810-1 Manubrio Deda Alanera
VO0810-3 Fsa Vision h.40 carbon
VO0810-4 Fsa Vision h.55 carbon

VO0820-1 Manubrio Deda Alanera
VO0820-3 Fsa Vision h. 40 carbon
VO0820-4 Fsa Vision h.55 carbon

VO0834-1 Manubrio Deda Alanera
VO0834-3 Fsa Vision h. 40 carbon
VO0834-4 Fsa Vision h.55 carbon

VO0832-1 Manubrio Deda Alanera
VO0832-2 Mavic Ksyrium 30 D
VO0832-3 Fsa Vision h. 40 carbon
VO0832-4 Fsa Vision h. 55 carbon

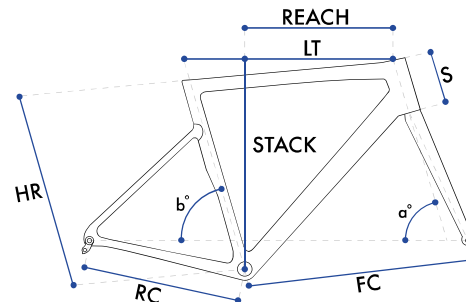

SIZE	460	490	510	530	560
HR	460	490	510	530	560
LT	515	536	548	565	587
RC	408	408	408	408	408
FC	576,5	579,2	583,2	596,7	611,2
a°	71,5°	72,5°	73°	73,5°	73,5°
b°	75°	74°	73,5°	73,2°	73°
S	110	120	140	160	180
REACH	379,1	384,2	387,6	397,2	406,2
STACK	509,7	522,8	541,6	562,7	587,7

GEPIN 4.0

VO0920-3 / Shimano Ultegra Di2 2x12 + Ruote Vision Carbon 40



COLORS



COLOR CONFIGURATOR

PESO
WEIGHT
PESO
POIDS

8,2 kg



COLORE IN FOTO
COLOR IN PICTURE

NERO-BIANCO C903

GEPIN 4.0

VO0934 / Shimano 105 Di2 2x12



COLORS



COLOR CONFIGURATOR

PESO
WEIGHT
PESO
POIDS

8,7 kg



COLORE IN FOTO
COLOR IN PICTURE

NERO-CELESTE C910

GEPIN 4.0

VO0932 / Shimano 105 2x12



COLORS



COLOR CONFIGURATOR



COLORE IN FOTO
COLOR IN PICTURE

NERO-ROSSO C907

PESO
WEIGHT
PESO
POIDS

8,6 kg

GEPIN 4.0

	TELAIO FRAME CADRE CUADRO	FORCELLA FORK FOURCHE HORQUILLA	CAMBIO GEARS CAMBIO POST. ARRIER DER.	DERAGL. DERAILLEUR CAMBIO ANT. AVANT DER.	COMANDI CONTROLS PALANCAS DE CAMBIO MANETTES	GUARN. CRANKSET BIELA PEDALIER	CASSETTA CASSETTE CASSETTE	FRENI BRAKES FRENOS FREINS	MANUBRIO HANDLEBAR MANILLAR GUIDON	RUOTE WHEELS RUEDAS ROUES	GOMME TYRES PNEUMATICOS PNEUS	SELLA SADDLE SELLE SILLIN	REGGISILLA SEAT POST TIGE DE SELLE TIJA
VO0910 Dura Ace Di2 2x12	Road Carbon monocoque	Carbon monocoque	Dura Ace 9250	Dura Ace 9250F	Dura Ace 9270	Dura Ace 9200 50-34	Dura Ace 9200 11-34	Dura Ace 9270	Deda Superbox / Deda Zerocento	Mavic Ksyrium 30 D	Vittoria Corsa N.EXT 700x28 TLR Tubeless	San Marco Shortfit	Deda Zerocento
VO0920 Ultegra Di2 2x12	Road Carbon monocoque	Carbon monocoque	Ultegra 8150	Ultegra 8150F	Ultegra 8170	Ultegra 8100 50-34	Ultegra 8100 11-34	Ultegra 8170	Deda Superbox / Deda Zerocento	Mavic Ksyrium 30 D	Vittoria Rubino PRO 700x28 TLR Tubeless	San Marco Shortfit	Deda Zerocento
VO0934 Shimano 105 Di2 2x12	Road Carbon monocoque	Carbon monocoque	Shimano 105 7150	Shimano 105 7150F	Shimano 105 7170	Shimano 105 7100 50-34	Shimano 105 7100 11-34	Shimano 105 7170	Deda Superbox / Deda Zerocento	Fulcrum R900 DB / Mavic Aksium	Vittoria Zaffiro Pro 700x25	San Marco Shortfit	Deda Zerocento
VO0932 Shimano 105 2x12	Road Carbon monocoque	Carbon monocoque	Shimano 105 7100	Shimano 105 7100F	Shimano 105 7120	Shimano 105 7100 50-34	Shimano 105 7100 11-34	Shimano 105 7120	Deda Superbox / Deda Zerocento	Fulcrum R900 DB / Mavic Aksium	Vittoria Zaffiro Pro 700x25	San Marco Shortfit	Deda Zerocento

COLORS

NERO-CELESTE C910

NERO-ROSSO C907

NERO-BIANCO C903

CHOOSE
YOUR
COLORS



COLOR CONFIGURATOR

OPTIONAL

VO0910-1 Manubrio Integrato
VO0910-3 Ruote Fsa Vision h. 40 carbon
VO0910-4 Ruote Fsa Vision h. 55 carbon

VO0920-1 Manubrio Integrato
VO0920-3 Ruote Fsa Vision h. 40 carbon
VO0920-4 Ruote Fsa Vision h. 55 carbon

VO0934-1 Manubrio Integrato
VO0934-2 Mavic Ksyrium 30 D
VO0934-3 Fsa Vision h. 40 carbon
VO0934-4 Fsa Vision h. 55 carbon

VO0932-1 Manubrio Integrato
VO0932-2 Mavic Ksyrium 30 D
VO0932-3 Fsa Vision h. 40 carbon
VO0932-4 Fsa Vision h. 55 carbon

OPTIONAL: Manubrio integrato / integrated stem-handlebar

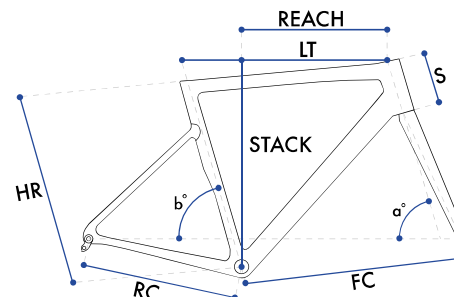

SIZE	430	470	500	530	560	585
HR	429,5	470,7	502,5	532,6	560	585
LT	515	529,4	545	566	585	605
RC	408	408	408	408	408	408
FC	576,6	579,3	585	595,9	603,7	623,3
a°	71°	72°	73°	73°	74°	74°
b°	74°	74°	73°	73°	72°	72°
s	110	125	145	170	205	220
REACH	373,4	378,1	382,4	390,2	392,4	407,8
STACK	510,9	529	548,4	575,3	610,6	625

GEPIN

VO0732 / Shimano 105 2x12



COLORS

GRIGIO OPACO C004

NERO OPACO C009

ARANCIO LUCIDO C030

PESO
WEIGHT
POIDS
PESO

8,6 kg



GEPIN

VO0730 / Shimano 105 2x11



COLORS

GRIGIO OPACO C004

NERO OPACO C009

ARANCIO LUCIDO C030

PESO
WEIGHT
POIDS
PESO

8,6 kg



GEPIN

VO0730 / Shimano 105 2x11



COLORS

GRIGIO OPACO C004

NERO OPACO C009

ARANCIO LUCIDO C030

PESO
WEIGHT
POIDS
PESO

8,6 kg



GEPIN

TELAIO
FRAME
CADRE
CUADRO

FORCELLA
FORK
FOURCHE
HORQUILLA

CAMBIO
GEARS
ARRIER DER.
CAMBIO POST.

DERAGL.
DERAILLEUR
AVANT DER.
CAMBIO ANT.

COMANDI
CONTROLS
MANETTES.
PALANCAS DE
CAMBIO

GUARN.
CRANKSET
PEDALIER
BIELA

CASSETTA
CASSETTE
CASSETTE
CASSETTE

FRENI
BRAKES
FREINS
FRENOS

MANUBRIO
HANDLEBAR
GUIDON
MANILLAR

RUOTE
WHEELS
ROUES
RUEDAS

GOMME
TYRES
PNEUS
PNEUMATICOS

SELLA
SADDLE
SELLE
SILLIN

REGGISELLA
SEAT POST
TIGE DE SELLE
TIJA

VO0720 Ultegra Di2 2x12	Road Carbon monocoque "Gepin" Normal weight	Carbon monocoque	Ultegra 8150	Ultegra 8150F	Ultegra 8170	Ultegra 8100 50-34	Ultegra 8100 11-34	Ultegra 8170	Deda Zero	Fulcrum R900 DB / Mavic Aksium	Vittoria Zaffiro Pro 700x25	Selle Italia X3 Boost	Deda Zero
VO0734 Shimano 105 Di2 2x12	Road Carbon monocoque "Gepin" Normal weight	Carbon monocoque	Shimano 105 7150	Shimano 105 7150F	Shimano 105 7170	Shimano 105 7100 50-34	Shimano 105 7100 11-34	Shimano 105 7170	Deda Zero	Fulcrum R900 DB / Mavic Aksium	Vittoria Zaffiro Pro 700x25	Selle Italia X3 Boost	Deda Zero
VO0732 Shimano 105 2x12	Road Carbon monocoque "Gepin" Normal weight	Carbon monocoque	Shimano 105 7100	Shimano 105 7100F	Shimano 105 7120	Shimano 105 7100 50-34	Shimano 105 7100 11-34	Shimano 105 7120	Deda Zero	Fulcrum R900 DB / Mavic Aksium	Vittoria Zaffiro Pro 700x25	Selle Italia X3 Boost	Deda Zero
VO0730 Shimano 105 2x11	Road Carbon monocoque "Gepin" Normal weight	Carbon monocoque	Shimano 105 7000	Shimano 105 7000F	Shimano 7020	Mov 50-34	Shimano 7000 11-30	Shimano 7020	Deda Zero	Fulcrum R900 DB / Mavic Aksium	Vittoria Zaffiro Pro 700x25	Selle Italia X3 Boost	Zeda Zero

GRIGIO OPACO C004

COLORS

NERO OPACO C009

ARANCIO LUCIDO C030

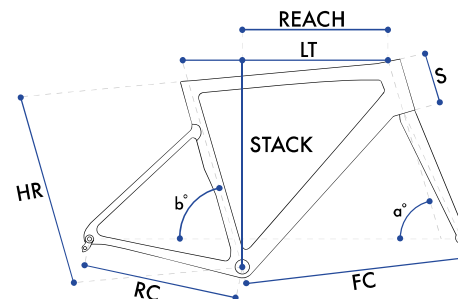

SIZE	430	470	500	530	560	585
HR	429,5	470,7	502,5	532,6	560	585
LT	515	529,4	545	566	585	605
RC	408	408	408	408	408	408
FC	576,6	579,3	585	595,9	603,7	623,3
a°	71°	72°	73°	73°	74°	74°
b°	74°	74°	73°	73°	72°	72°
S	110	125	145	170	205	220
REACH	373,4	378,1	382,4	390,2	392,4	407,8
STACK	510,9	529	548,4	575,3	610,6	625

911TT TRIATHLON

VO1324 / Ultegra 2x11

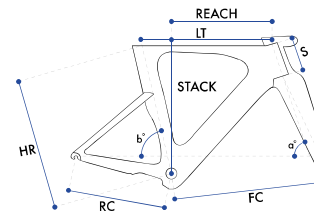

SIZE	500	520	550	580	600
HR	505	525	549	577	600
LT	480	505	530	560	585
RC	395	395	395	395	395
FC	570	586	609	636	663
a°	70,3°	71,5°	72°	72,5°	72,5°
b°	77°	77°	77°	77°	77°
S	100	115	140	165	190
REACH	364,8	385,5	404,6	428,7	448
STACK	499,2	517,7	543,1	568,7	593

OPTIONAL VO1324-4 con ruote FSA Metron 81 carbon

COLORS NERO-BLU C096

PESO
WEIGHT
POIDS
PESO

8,9 kg



TELAIO
FRAME
CADRE
CUADRO

FORCELLA
FORK
FOURCHE
HORQUILLA

CAMBIO
GEARS
ARRIER DER.
CAMBIO POST.

DERAGL.
DERAILLEUR
AVANT DER.
CAMBIO ANT.

COMANDI
CONTROLS
MANETTES.
PALANQUES DE
CAMBIO

GUARN.
CRANKSET
PEDALIER
BIELA

CASSETTA
CASSETTE
CASSETTE
CASSETTE

FRENI
BRAKES
FREINS
FRENOS

MANUBRIO
HANDLEBAR
GUIDON
MANILLAR

RUOTE
WHEELS
ROUES
RUEDAS

GOMME
TYRES
PNEUS
PNEUMATICOS

SELLA
SADDLE
SELLE
SILLIN

REGGISSELLA
SEAT POST
TIGE DE SELLE
TIJA

VO1324
Ultegra

Olmo Carbon
aereo TT

Olmo Carbon
aereo TT

Ultegra 8000

Ultegra 8000F

Shimano BSR1x1

Ultegra 8000
50-34

Ultegra 8000
11-30

TRP TTV09

Olmo Carbon
TT

FSA Team 35

Vittoria Rubino
Pro 700x25

Selle Italia
Iron

Olmo Carbon
Aereo

911TE CRONO

VO1324-C / Ultegra 2x11

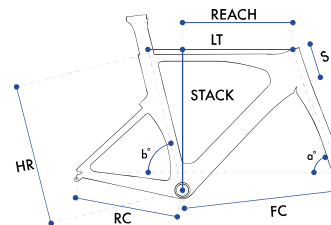

SIZE	450	530	540	557	576
HR	450	530	540	557	576
LT	490	511	531	550	569
RC	395	395	395	395	395
FC	562	563	584	603	622
a°	71°	72,5°	72,5°	72,5°	72,5°
b°	75°	75°	75°	75°	75°
S	91	101	111	129	148
REACH	372	378	396	410	424
STACK	453	512	521	538	556

OPTIONAL VO1324-C4 con ruote FSA Metron 81 carbon

COLORS BIANCO-ROSSO C037

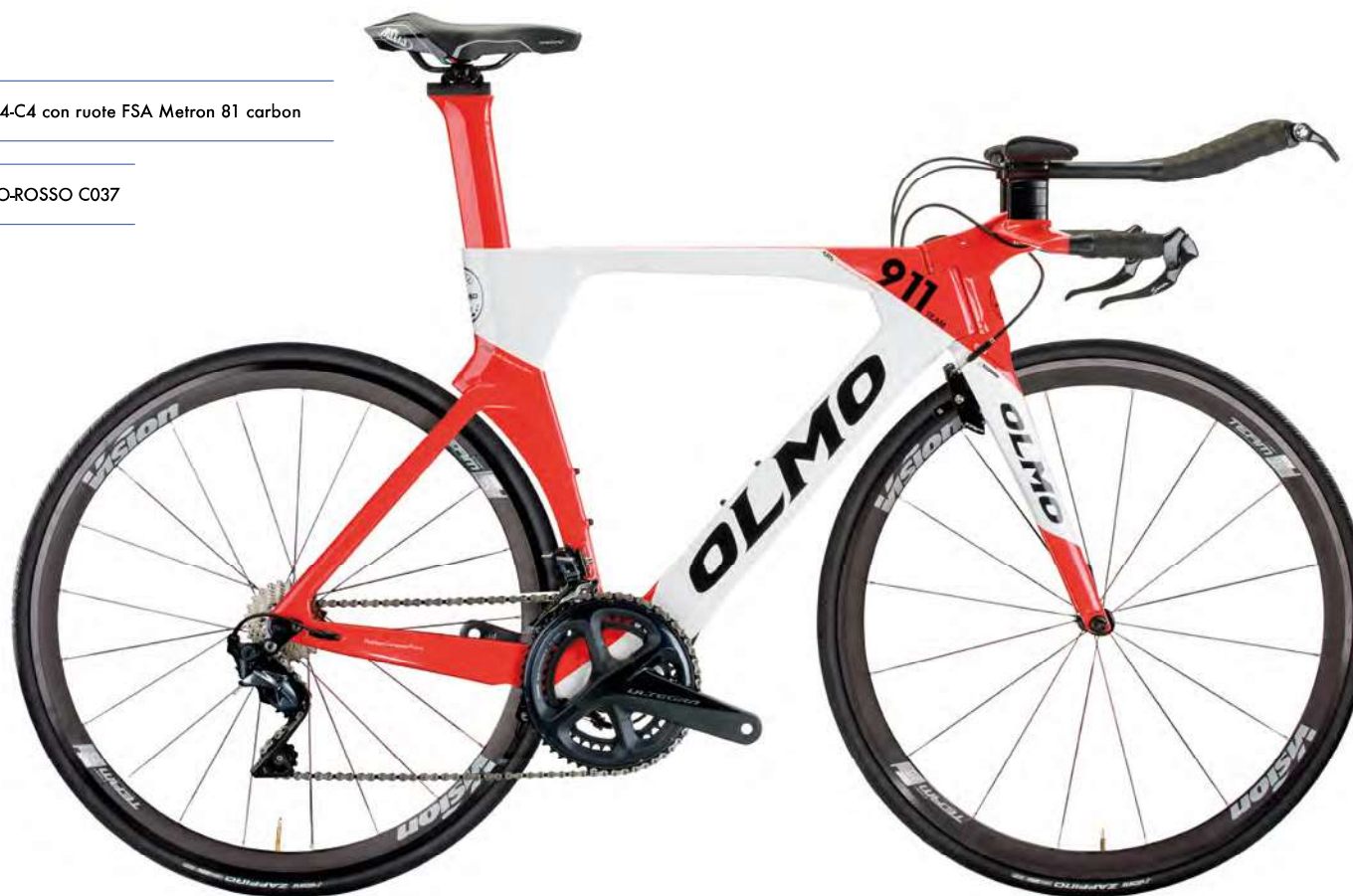

PESO
WEIGHT
POIDS
PESO

8,9 kg



TELAIO
FRAME
CADRE
CUADRO

FORCELLA
FORK
FOURCHE
HORQUILLA

CAMBIO
GEARS
ARRIER DER.
CAMBIO
POST.

DERAGL.
DERAILLEUR
AVANT DER.
CAMBIO ANT.

COMANDI
CONTROLS
MANETTES.
PALANQUES DE
CAMBIO

GUARN.
CRANKSET
PEDALIER
BIELA

CASSETTA
CASSETTE
CASSETTE
CASSETTE

FRENI
BRAKES
FREINS
FRENOS

MANUBRIO
HANDLEBAR
GUIDON
MANILLAR

RUOTE
WHEELS
ROUES
RUEDAS

GOMME
TYRES
PNEUS
PNEUMATICOS

SELLA
SADDLE
SELLE
SILLIN

REGGISSELLA
SEAT POST
TIGE DE SELLE
TUA

VO1324-C
Ultegra

Olmo Carbon
crono

Olmo Carbon
crono

Ultegra 8000

Ultegra 8000F

Shimano
BSR1x1

Ultegra 8000
50-34

Ultegra 8000
11-30

TRP TTV09

Olmo Carbon
TT

FSA Team 35

Vittoria Rubino Pro
700x25

Selle Italia Iron

Olmo Carbon
Aereo

ZERODIECI

VO1533 / Shimano 105 Mix 2x11



PESO
WEIGHT
POIDS
PESO

8,5 kg

TELAIO
FRAME
CADRE
CUADRO

FORCELLA
FORK
FOURCHE
HORQUILLA

CAMBIO
GEARS
ARRIER DER.
CAMBIO POST.

DERAGL.
DERAILLEUR
AVANT DER.
CAMBIO ANT.

COMANDI
CONTROLS
MANETTES.
PALANCAS DE
CAMBIO

GUARN.
CRANKSET
PEDALIER
BIELA

CASSETTA
CASSETTE
CASSETTE
CASSETTE

FRENI
BRAKES
FREINS
FRENOS

MANUBRIO
HANDLEBAR
GUIDON
MANILLAR

RUOTE
WHEELS
ROUES
RUEDAS

GOMME
TYRES
PNEUS
PNEUMATICOS

SELLA
SADDLE
SELLE
SILLIN

REGGISELLA
SEAT POST
TIGE DE SELLE
TIJA

ROAD

VO1533 Shimano 105 Mix 2X11	Road Carbon monocoque "Zerodiecì"	Carbon "Zerodiecì"	Shimano 105 7000	Shimano 105 7000F	Shimano 105 7000	Mov 50-34	Shimano 105 7000 11-30	Shimano R561	Deda Zero	Olmo Vita	Vittoria Zaffiro 700x25	Selle Italia X3 Boost	Deda Zero
VO1543 Shimano Tiagra Mix 2X10	Road Carbon monocoque "Zerodiecì"	Carbon "Zerodiecì"	Tiagra 4700	Tiagra 4700F	Tiagra 4700	Mov 50-34	Shimano 11-34	Alloy	Deda Zero	Olmo Vita	Vittoria Zaffiro 700x25	Selle Italia X3 Boost	Deda Zero

SPORT

VO1433 Shimano 105 mix 2x11 Sport	Road Carbon monocoque "Zerodiecì"	Carbon "Zerodiecì"	Shimano 105 7000	Shimano 105 7000F	Shimano RS700 Flat	Mov 50-34	Shimano 105 7000 11-30	Shimano R561	Deda Zero Flat	Olmo Vita	Vittoria Zaffiro 700x25	Selle Italia X3 Boost	Alloy
VO1443 Shimano Tiagra Mix 2X10 Sport	Road Carbon monocoque "Zerodiecì"	Carbon "Zerodiecì"	Tiagra 4700	Tiagra 4700F	Tiagra 4700 Flat	Mov 50-34	Shimano 11-34	Alloy	Deda Zero Flat	Olmo Vita	Vittoria Zaffiro 700x25	Selle Italia X3 Boost	Alloy

ZERODIECI

VO1543 / Shimano Tiagra Mix 2x10

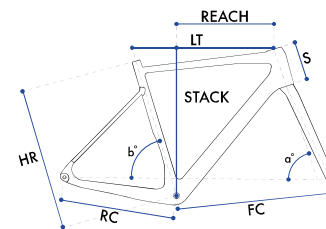

SIZE	470	500	530	560	590
HR	470	500	530	560	590
LT	515	530	545	565	585
RC	408	408	408	408	408
FC	578	579,6	584,9	609,9	612,2
a°	72°	72,5°	72,5°	73°	73°
b°	75,5°	74,5°	73,5°	73°	72,75°
S	110	125	140	160	180
REACH	382,6	383,6	384,4	407,9	404,4
STACK	511,6	527,5	541,8	562,7	581,8

COLORS

ROSSO METALLIZZATO C018

TURCHESE METALLIZZATO C019



PESO
WEIGHT
POIDS
PESO

8,6 kg

ZEROCINQUE

VO1633 / Shimano 105 Mix 2x11



PESO
WEIGHT
POIDS
PESO

9,6 kg

	TELAIO FRAME CADRE CUADRO	FORCELLA FORK FOURCHE HORQUILLA	CAMBIO GEARS ARRIER DER. CAMBIO POST.	DERAGL. DERAILLEUR AVANT DER. CAMBIO ANT.	COMANDI CONTROLS MANETTES. PALANCAS DE CAMBIO	GUARN. CRANKSET PEDALIER BIELA	CASSETTA CASSETTE CASSETTE CASSETTE	FRENI BRAKES FREINS FRENOS	MANUBRIO HANDLEBAR GUIDON MANILLAR	RUOTE WHEELS ROUES RUEDAS	GOMME TYRES PNEUS PNEUMATICOS	SELLA SADDLE SELLE SILLIN	REGGISSELLA SEAT POST TIGE DE SELLE TIJA
ROAD													
VO1633 Shimano 105 Mix 2x11	Road Alloy "Zerocinque"	Carbon "Zerocinque"	Shimano 105 7000	Shimano 105 7000F	Shimano 105 7000	Mov 50-34	Shimano 7000 11-30	Shimano R561	Deda Zero	Olmo Vita	Vittoria Zaffiro 700x25	Selle Italia X3 Boost	Alloy
VO1643 Shimano Tiagra Mix 2x10	Road Alloy "Zerocinque"	Carbon "Zerocinque"	Tiagra 4700	Tiagra 4700F	Tiagra 4700	Mov 50-34	Shimano 11-34	Alloy	Deda Zero	Olmo Vita	Vittoria Zaffiro 700x25	Selle Italia X3 Boost	Alloy
SPORT													
VO1733 Shimano 105 Mix 2x11 Sport	Road Alloy "Zerocinque"	Carbon "Zerocinque"	Shimano 105 7000	Shimano 105 7000F	Shimano RS700 Flat	Mov 50-34	Shimano 7000 11-30	Shimano R561	Deda Zero Flat	Olmo Vita	Vittoria Zaffiro 700x25	Selle Italia X3 Boost	Alloy
VO1743 Shimano Tiagra Mix 2x10 Sport	Road Alloy "Zerocinque"	Carbon "Zerocinque"	Tiagra 4700	Tiagra 4700F	Tiagra 4700 Flat	Mov 50-34	Shimano 11-34	Alloy	Deda Zero Flat	Olmo Vita	Vittoria Zaffiro 700x25	Selle Italia X3 Boost	Alloy

ZEROCINQUE

VO1643 / Shimano Tiagra Mix 2x10

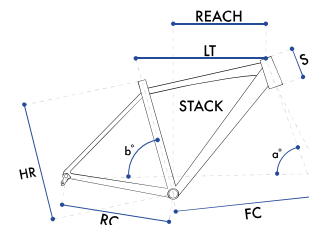

SIZE	450	510	550	580
HR	450	510	550	580
LT	506,1	534,4	552,6	584,8
RC	410	410	410	410
FC	573,9	595	616	641,5
a°	72°	72°	72°	72°
b°	74,5°	74,5°	74,5°	74,5°
S	130	130	175	175

COLORS

NEROGIALLO C092

NERO-ROSSO C097



PESO
WEIGHT
POIDS
PESO

9,7 kg

NERAX

VO-K08



GEPIN 4.0

VO-K09



GEPIN

VO-K07



911TE

VO-K13C



911TT

VO-K13



BORMIDA

VO1935 / Shimano GRX 2x12



PESO
WEIGHT
POIDS
PESO

9,9 kg

BORMIDA

VO1936 / Shimano GRX 1x12

COLORS

VERDE MENTA C013

PETROLIO C015



PESO
WEIGHT
POIDS
PESO

9,7 kg

BORMIDA

COLORS

VERDE MENTA C013

PETROLIO C015

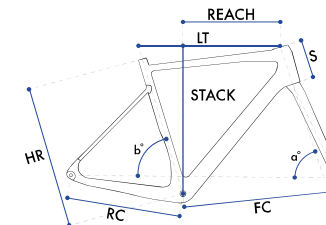

SIZE	490	520	540	560	590
HR	490	520	540	560	590
LT	525	535	545	560	585
RC	435	435	435	435	435
FC	592	593	595,5	601	612
a°	70,5°	71°	71,5°	72°	72,5°
b°	74°	73,5°	73°	72,5°	72,5°
S	125	140	150	170	190
REACH	369	370	371,4	374	379
STACK	538	556	568	589	606

	TELAIO FRAME CADRE CUADRO	FORCELLA FORK FOURCHE HORQUILLA	CAMBIO GEARS ARRIER DER. CAMBIO POST.	DERAGL. DERAILLEUR AVANT DER. CAMBIO ANT.	COMANDI CONTROLS MANETTES. PALANCAS DE CAMBIO	GUARN. CRANKSET PEDALIER BIELA	CASSETTA CASSETTE CASSETTE CASSETTE	FRENI BRAKES FREINS FRENOS	MANUBRIO HANDLEBAR GUIDON MANILLAR	RUOTE WHEELS ROUES RUEDAS	GOMME TYRES PNEUS PNEUMATICOS	SELLA SADDLE SELLE SILLIN	REGGISELLA SEAT POST TIGE DE SELLE TIJA
VO1936 Shimano Grx 1X12	Gravel Carbon "Bormida"	Carbon monocoque "Bormida"	Shimano GRX RX- 822GS	-	Shimano GRX RX-610	Shimano FC-R610 40T / FSA 40T	Shimano 7100 11-34	Shimano GRX RX-610	Deda Zero / Gravel100	Mavic Speedcity / Fulcrum R900DB	Kenda Gabbro 700x40	Selle Italia X3 Boost Superflow	Deda Zero
VO1935 Shimano Grx 2x12	Gravel Carbon "Bormida"	Carbon monocoque "Bormida"	Shimano GRX RX-822GS	Shimano GRX RX-820F	Shimano GRX RX-610	FSA Omega 46-30	Shimano HG700 11-34	Shimano GRX RX-610	Deda Zero / Gravel100	Mavic Speedcity / Fulcrum R900DB	Kenda Gabbro 700x40	Selle Italia X3 Boost Superflow	Deda Zero
VO1930 Shimano Grx 2x10	Gravel Carbon "Bormida"	Carbon monocoque "Bormida"	Shimano GRX RX-400	Shimano GRX RX-400F	Shimano RX-400	Alloy 48/32	Shimano HG500 11-34	Shiman RX-400	Deda Zero / Gravel100	MOV gravel	Kenda Gabbro 700x40	Selle Italia X3 Boost Superflow	Deda Zero

X-TRADA GRAVEL

VO1835 / Shimano GRX 2x12

COLORS

GRIGIO-ROSSO C047

GRIGIO-NERO C049



PESO
WEIGHT
POIDS
PESO

10,6 kg

X-TRADA SPORT

VO1800 / Shimano Tiagra Mix 2x10



PESO
WEIGHT
POIDS
PESO

10,7 kg

X-TRADA

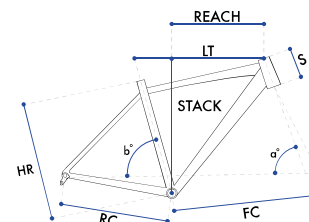

SIZE	470	510	540	570
HR	470	510	540	570
LT	502,4	529,9	543,5	564,2
RC	435	435	435	435
FC	593	620,1	617	628,1
a°	70°	71°	71°	71,5°
b°	74,5°	73,5°	73,5°	73°
S	120	140	160	180
REACH	367,9	397	387,5	396,7
STACK	544,1	566,8	585,7	606,6

COLORS

GRIGIO-ROSSO C047

GRIGIO-NERO C049



TELAIO
FRAME
CADRE
CUADRO

FORCELLA
FORK
FOURCHE
HORQUILLA

CAMBIO
GEARS
ARRIER DER.
CAMBIO
POST.

DERAGL.
DERAILLEUR
AVANT DER.
CAMBIO
ANT.

COMANDI
CONTROLS
MANETTES.
PALANCAS
DE CAMBIO

GUARN.
CRANKSET
PEDALIER
BIELA

CASSETTA
CASSETTE
CASSETTE

FRENI
BRAKES
FREINS
FRENOS

MANUBRIO
HANDLEBAR
GUIDON
MANILLAR

RUOTE
WHEELS
ROUES
RUEDAS

GOMME
TYRES
PNEUS
PNEUMATICOS

SELLA
SADDLE
SELLE
SILLIN

REGGISSELLA
SEAT POST
TIGE DE SELLE
TIJA

GRAVEL

VO1835 Shimano Grx 2x12	Gravel Alloy "Xtrada"	Carbon monocoque "X-trada"	Shimano GRX RX-822GS	Shimano GRX RX-820F	Shimano GRX RX-610	FSA Omega 46-30	Shimano HG700 11-34	Shimano GRX RX-610	Deda Zero / Gravel 100	MOV gravel	Kenda Gabbro 700x40	Selle Italia X3 Boost Superflow	Deda Zero
VO1830 Shimano Grx 2x10	Gravel Alloy "Xtrada"	Carbon monocoque "X-trada"	Shimano GRX RX-400	Shimano GRX RX-400F	Shimano RX-400	Alloy 48/32	Shimano HG500 11-34	Shimano RX-400	Deda Zero / Gravel 100	MOV gravel	Kenda Gabbro 700x40	Selle Italia X3 Boost Superflow	Alloy

SPORT

VO1805 Shimano 105 Mix 2x11 Sport	Gravel Alloy "Xtrada"	Carbon monocoque "X-trada"	Shimano 105 7000	Shimano 105 7000F	Shimano RS700 Flat	Mov 50-34	Shimano 7000 11-30	Shimano RS600	Deda Zero / Alloy Flat	MOV Gravel	Kenda Gabbro 700x40	Selle Italia X3 Boost Superflow	Alloy
VO1800 Tiagra Mix 2x10 Sport	Gravel Alloy "Xtrada"	Carbon monocoque "X-trada"	Shimano Tiagra 4700	Tiagra 4700F	Shimano SL-4700 Flat	Mov 50-34	Shimano HG500 11-34	Shimano RS 600	Deda Zero / Alloy Flat	MOV Gravel	Kenda Gabbro 700x40	Selle Italia X3 Boost Superflow	Alloy

MTB

The peak climbers



BIGNONE

VO2120 / Shimano Deore 1x11

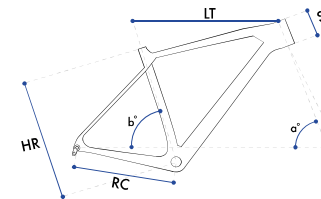

SIZE	430	480	530
HR	432	480	530
LT	595	617	639
RC	440	440	440
a°	68,5°	68,5°	68,5°
b°	72,5°	72,5°	72,5°
S	105	110	115

PESO
WEIGHT
POIDS
PESO

12,9 kg

	TELAIO FRAME CADRE CUADRO	FORCELLA FORK FOURCHE HORQUILLA	CAMBIO GEARS ARRIER DER. CAMBIO POST.	DERAGL. DERAILLEUR AVANT DER. CAMBIO ANT.	COMANDI CONTROLS MANETTES. PALANCS DE CAMBIO	GUARN. CRANKSET PEDALIER BIELA	CASSETTA CASSETTE CASSETTE CASSETTE	FRENI BRAKES FREINS FRENOS	MANUBRIO HANDLEBAR GUIDON MANILLAR	RUOTE WHEELS ROUES RUEDAS	GOMME TYRES PNEUS PNEUMATICOS	SELLA SADDLE SELLE SILLIN	REGGISELLA SEAT POST TIGE DE SELLE TUA
VO2132 Shimano XT 1x12	MTB Carbon monocoque "Bignone"	Rock Shox REBA RL axle 15/110 esc. 120mm	Shimano XT M8100GS	-	Shimano XT M8100	Shimano MT510 34T	Shimano M7000 11-51 / Sunrace 11-50	Formula Cura 180/160	Deda Mud Peak	Shimano MT501 / MOV XC-29 15/110 12/148	Vittoria Barzo 29*2.25	Selle Italia X-LR Air Cross	Deda Mud Peak
VO2112 Sram Sx Eagle 1x12	MTB Carbon monocoque "Bignone"	Rock Shox Judy Tk 15/110	Sram SX Eagle	-	Sram SX Eagle Trigger	Sram SX Eagle 30T	Sram SX 11-50	Formula Cura 180/160	Mov alloy	MOV XC-29 15/110 12/148	Vittoria Barzo 29*2.25	Selle Italia Model X Flow	Alloy
VO2120 Shimano Deore 1x11	MTB Carbon monocoque "Bignone"	Rock Shox Judy Tk 15/110	Shimano Deore M5100	-	Shimano Deore	Shimano M-5100 32T	Shimano Deore 11-51	Shimano M-200 180/160	Mov alloy	MOV XC-29 15/110 12/148	Vittoria Barzo 29*2.25	Selle Italia Model X Flow	Alloy

BIGNONE

VO2132 / Shimano XT 1x12

COLORS

AZZURRO CHIARO-NERO C109

SABBIA-VERDE OLIVA C814



PESO
WEIGHT
POIDS
PESO

11,6 kg

HETNA

VO2620 / Shimano Deore 1x11

COLORS

VERDE MILITARE C014

BLU C006



PESO
WEIGHT
POIDS
PESO

16,3 Kg

	TELAIO FRAME CADRE CUADRO	FORCELLA FORK FOURCHE HORQUILLA	AMMORTIZ- ZATORE	CAMBIO GEARS ARRIER DER. CAMBIO POST.	COMANDI CONTROLS MANETTES. PALANCAS DE CAMBIO	GUARN. CRANKSET PEDALIER BIELA	CASSETTA CASSETTE CASSETTE CASSETTE	FRENI BRAKES FREINS FRENOS	MANUBRIO HANDLEBAR GUIDON MANILLAR	RUOTE WHEELS ROUES RUEDAS	GOMME TYRES PNEUS PNEUMATICOS	SELLA SADDLE SELLE SILLIN	REGGISSELLA SEAT POST TIGE DE SELLE TIJA
VO2632 Shimano XT 1x12	MTB full susp. "Hetna"	Rock Shox Judy S TK 130mm	Rock Shox DLX SEL+	Shimano XT M8100GS	Shimano XT M8100	Shimano MT510 34T	Shimano M7000 11-51 / Sunrace 11-50	Promax 4 pistoni 203/180	Mov alloy	Shimano MT501 / MOV XC-29 15/110 12/148	Vittoria Barzo 29*2.25	Selle Italia Model X Flow	Telescopic Promax
VO2610 Sram SX Eagle 1x12	MTB full susp. "Hetna"	Rock Shox Judy S TK 130mm	Rock Shox DLX SEL+	Sram SX Eagle	Sram SX Eagle Trigger	Sram SX Eagle 30T	Sram SX 11-50	Promax 4 pistoni 203/180	Mov alloy	MOV XC-29 15/110 12/148	Vittoria Barzo 29*2.25	Selle Italia Model X Flow	Telescopic Promax
VO2621 Shimano Deore 1x11 15/12	MTB full susp. "Hetna"	Rock Shox Judy S TK 130mm	Rock Shox DLX SEL+	Shimano Deore M5100	Shimano Deore	Shimano M-5100 32T	Shimano Deore 11-51	Promax 4 pistoni 203/180	Mov alloy	MOV XC-29 15/110 12/148	Vittoria Barzo 29*2.25	Selle Italia Model X Flow	Telescopic Promax
VO2611 Sram SX Eagle 1x12	MTB full susp. "Hetna"	Rock Shox Judy S TK 130mm	Rock Shox DLX SEL+	Sram SX Eagle	Sram SX Eagle Trigger	Sram SX Eagle 30T	Sram SX 11-50	Shimano M-200 180/160	Mov alloy	MOV XC-29 Q/R	Kenda 29*2.25	Selle Italia X-base	Alloy
VO2620 Shimano Deore 1x11	MTB full susp. "Hetna"	Rock Shox Judy S TK 130mm	Rock Shox DLX SEL+	Shimano Deore M5100	Shimano Deore	Shimano M-5100 32T	Shimano Deore 11-51	Shimano M-200 180/160	Mov alloy	MOV XC-29 Q/R	Kenda 29*2.25	Selle Italia X-base	Alloy

HETNA

VO2610 / Sram Sx Eagle 1x12

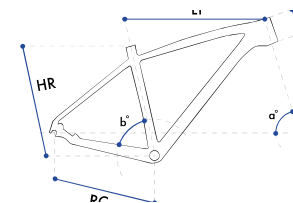

SIZE	420	470	520
HR	420	470	520
LT	520	520	610
RC	460	460	460
a°	71°	71°	71°
b°	73°	73°	73°
S	120	130	140



PESO
WEIGHT
POIDS
PESO

16,8 Kg

CARMO

VO2011 / Sram SX Eagle 1x12

COLORS

GRIGIO-ROSSO C047

NERO-LIME C913



PESO
WEIGHT
POIDS
PESO

14,8 kg

	TELAIO FRAME CADRE CUADRO	FORCELLA FORK FOURCHE HORQUILLA	CAMBIO GEARS ARRIER DER. CAMBIO POST.	DERAGL. DERAILLEUR AVANT DER. CAMBIO ANT.	COMANDI CONTROLS MANETTES. PALANCAS DE CAMBIO	GUARN. CRANKSET PEDALIER BIELA	CASSETTA CASSETTE CASSETTE CASSETTE	FRENI BRAKES FREINS FRENOS	MANUBRIO HANDLEBAR GUIDON MANILLAR	RUOTE WHEELS ROUES RUEDAS	GOMME TYRES PNEUS PNEUMATICOS	SELLA SADDLE SELLE SILLIN	REGGISELLA SEAT POST TIGE DE SELLE TIJA
VO2010 Sram SX Eagle 1x12 15/12	Mtb Front 29" Alloy custom Olmo "Carmo"	Rock Shox Judy S TK	Sram SX Eagle	-	Sram SX Eagle Trigger	Sram SX Eagle 30T	Sram SX 11-50	Shimano M-200 180/160	Alloy	Mov 29" 15/12	Vittoria Barzo 29*2.25	Selle Italia Model-X Flow	Alloy
VO2021 Shimano Deore 1x11 15/12	Mtb Front 29" Alloy custom Olmo "Carmo"	Rock Shox Judy S TK	Shimano Deore	-	Shimano Deore	Shimano Deore FC5100	Shimano Deore 11-51	Shimano M-200 180/160	Alloy	Mov 29" 15/12	Vittoria Barzo 29*2.25	Selle Italia Model-X Flow	Alloy
VO2011 Sram SX Eagle 1x12	Mtb Front 29" Alloy custom Olmo "Carmo"	Suntour XCM RL Hydriaulic / RST Blaze RL	Sram SX Eagle	-	Sram SX Eagle Trigger	Sram SX Eagle 30T	Sram SX 11-50	Shimano M-200 180/160	Alloy	Mov 29" Q/R	Kenda 29*2.25	Selle Italia X-base	Alloy
VO2020 Shimano Deore 1x11	Mtb Front 29" Alloy custom Olmo "Carmo"	Suntour XCM RL Hydriaulic / RST Blaze RL	Shimano Deore	-	Shimano Deore	Shimano Deore FC5100	Shimano Deore 11-51	Shimano M-200 180/160	Alloy	Mov 29" Q/R	Kenda 29*2.25	Selle Italia X-base	Alloy
VO2050 Shimano Deore 2x10	Mtb Front 29" Alloy custom Olmo "Carmo"	Suntour XCM RL Hydriaulic / RST Blaze RL	Shimano Deore	Shimano Deore	Shimano Deore	Alloy Mov 36-22	Shimano Deore 11-42	Shimano M-200 180/160	Alloy	Mov 29" Q/R	Kenda 29*2.25	Selle Italia X-base	Alloy

CARMO

VO2021 / Shimano Deore 1x11 15/12

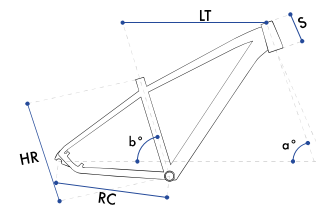

SIZE	420	470	520
HR	420	470	520
LT	570	590	610
RC	460	460	460
a°	71°	71°	71°
b°	73°	73°	73°
S	120	130	140

PESO
WEIGHT
POIDS
PESO

13,8 kg



TURCHINO 29"

VO2370 / Shimano Acera 3x8

COLORS

ROSSO-NERO C097

NERO-LIME C913



PESO
WEIGHT
POIDS
PESO

15,7 kg

	TELAIO FRAME CADRE CUADRO	FORCELLA FORK FOURCHE HORQUILLA	CAMBIO GEARS ARRIER DER. CAMBIO POST.	DERAGL. DERAILLEUR AVANT DER. CAMBIO ANT.	COMANDI CONTROLS MANETTES. PALANCAS DE CAMBIO	GUARN. CRANKSET PEDALIER BIELA	CASSETTA CASSETTE CASSETTE CASSETTE	FRENI BRAKES FREINS FRENOS	MANUBRIO HANDLEBAR GUIDON MANILLAR	RUOTE WHEELS ROUES RUEDAS	GOMME TYRES PNEUS PNEUMATICOS	SELLA SADDLE SELLE SILLIN	REGGISSELLA SEAT POST TIGE DE SELLE TIJA
VO2311 Sram SX Eagle 1x12	MTB 29" Alloy 6061 custom Olmo	Suntour XCM RL Hydraulic / RST Blaze RL	Sram SX Eagle	-	Sram SX Eagle Trigger	Sram SX Eagle 30T	Sram SX 11-50	Disco idraulico	Alloy	Mov 29"	29*2.20	Selle Italia X-base	Alloy
VO2340 Shimano Deore 1x11	MTB 29" Alloy 6061 custom Olmo	Suntour XCM RL Hydraulic / RST Blaze RL	Shimano Deore	-	Shimano Deore	Shimano Deore FC5100	Shimano Deore 11-51	Disco idraulico	Alloy	Mov 29"	29*2.20	Selle Italia X-base	Alloy
VO2350 Shimano Deore 2x10	MTB 29" Alloy 6061 custom Olmo	Suntour XCM RL Hydraulic / RST Blaze RL	Shimano Deore	Shimano	Shimano Deore	Alloy Mov 36/22	Shimano Deore 11-42	Disco idraulico	Alloy	Mov 29"	29*2.20	Selle Italia X-base	Alloy
VO2370 Shimano Acera 3x8	MTB 29" Alloy 6061 custom Olmo	Suntour XCT HLO Hydraulic / RST Blaze ML	Shimano Acera	Shimano	Shimano SL M-315	Alloy Mov 42/34/24	Shimano HG31-8	Disco idraulico	Alloy	Mov 29"	29*2.20	Royal Mach	Alloy

TURCHINO 29"

VO2340 / Shimano Deore 1x11

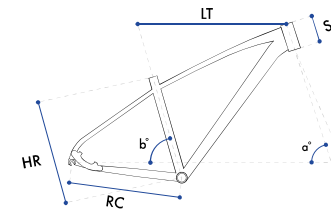

SIZE	425	475	525
HR	425	475	525
LT	585	600	617
RC	450	450	450
α°	72°	72°	72°
β°	74°	74°	74°
S	110	125	145

PESO
WEIGHT
POIDS
PESO

15,2 kg



GIOVI 27,5"

VO2480 / 3x7

COLORS

GRIGIO-GIALLO C042

NERO-BLU-BIANCO C963



PESO
WEIGHT
POIDS
PESO

15 kg

	TELAIO FRAME CADRE CUADRO	FORCELLA FORK FOURCHE HORQUILLA	CAMBIO GEARS ARRIER DER. CAMBIO POST.	DERAGL. DERAILLEUR AVANT DER. CAMBIO ANT.	COMANDI CONTROLS MANETTES. PALANCAS DE CAMBIO	GUARN. CRANKSET PEDALIER BIELA	CASSETTA CASSETTE CASSETTE CASSETTE	FRENI BRAKES FREINS FRENOS	MANUBRIO HANDLEBAR GUIDON MANILLAR	RUOTE WHEELS ROUES RUEDAS	GOMME TYRES PNEUS PNEUMATICOS	REGGISELLA SEAT POST TIGE DE SELLE TIJA
VO2450 2x10	MTB 27,5" Alloy 6061 custom Olmo	Suntour XCM RL Hydraulic / RST Blaze RL	Shimano Deore	Shimano	Shimano Deore	Alu Mov 36/22	Shimano Deore 11-42	Disco idraulico	Alloy	Mov 27,5"	27,5*2.20	Alloy
VO2470 3x8	MTB 27,5" Alloy 6061 custom Olmo	Suntour XCT HLO Hydraulic / RST Blaze ML	Shimano Acera	Shimano	Shimano SL M-315	Alu MOV 42/34/24	Shimano HG31-8	Disco idraulico	Alloy	Mov 27,5"	27,5*2.20	Alloy
VO2480 3x7	MTB 27,5" Alloy 6061 custom Olmo	CH-525 HLO	Shimano TY-300	Shimano	Shimano ST EF-51	Alu MOV 42/34/24	Shimano TZ500	Disco meccanico	Alloy	Mov 27,5"	27,5*2.20	Alloy
VO2490 3x7 V-brake	MTB 27,5" Alloy 6061 custom Olmo	CH-389 ML	Shimano TY-300	Shimano	Shimano ST EF-51	Alu MOV 42/34/24	Shimano TZ500	V-Brake Alloy	Alloy	Alloy 27,5" doppia camera / dual chamber	27,5*2.20	Alloy

GIOVI 27,5"

VO2470 / 3x8

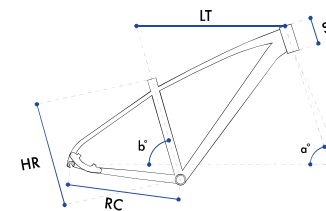

SIZE	390	425	475	525
HR	390	425	475	525
LT	570	580	592	615
RC	440	440	440	440
a°	71°	71°	71°	71°
b°	74°	74°	74°	74°
S	120	120	120	120

PESO
WEIGHT
POIDS
PESO

15,3 kg







E-BIKES

Faster, greater range



APP



SHIMANO
E-TUBE PROJECT CYCLIST

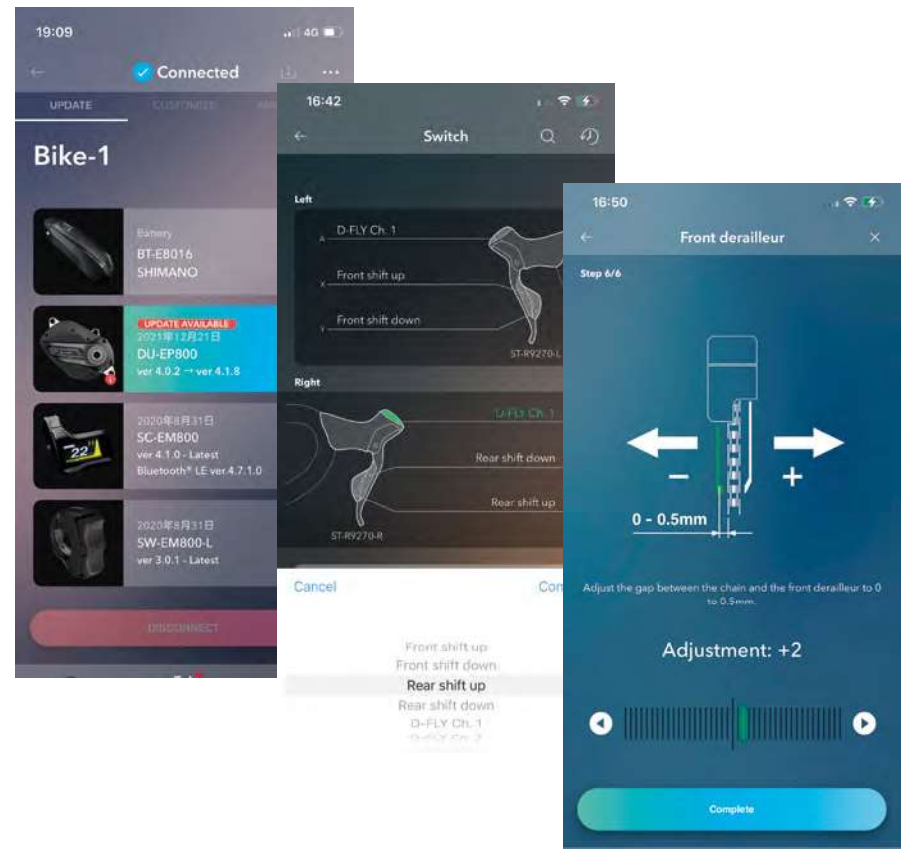

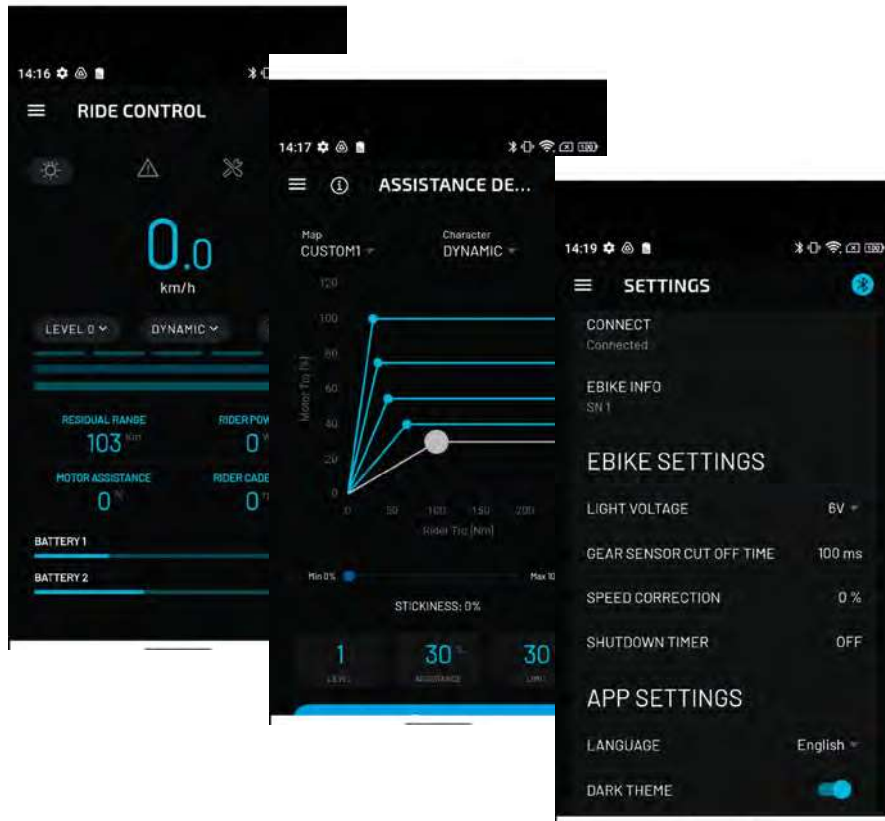

E-BRO 2.0

	TELAIO FRAME CADRE CUADRO	FORCELLA FORK FOURCHE HORQUILLA	CAMBIO GEARS ARRIER DER. CAMBIO POST.	DERAGL. DERAILLEUR AVANT DER. CAMBIO ANT.	COMANDI CONTROLS MANETTES. PALANCAS DE CAMBIO	GUARN. CRANKSET PEDALIER BIELA	CASSETTA CASSETTE CASSETTE CASSETTE	FRENI BRAKES FREINS FRENOS	MANUBRIO HANDLEBAR GUIDON MANILLAR	RUOTE WHEELS ROUES RUEDAS	GOMME TYRES PNEUS PNEUMATICOS	SELLA SADDLE SELLE SILLIN	REGGISSELLA SEAT POST TIGE DE SELLE TIJA
VO4410 Dura Ace Di2 2x12	Road Carbon monocoque custom Olmo	Carbon monocoque custom Olmo	Dura Ace 9250SS	Dura Ace 9250F	Dura Ace 9270	Alloy 50-34	Dura Ace 9200 11-34	Dura Ace 9270	Deda Superbox / Deda Zero	Fulcrum Racing R400DB / Mavic Ksyrium	Vittoria Zaffiro Pro 700*28	San Marco Shortfil	Carbon
VO4420 Ultegra Di2 2x12	Road Carbon monocoque custom Olmo	Carbon monocoque custom Olmo	Ultegra 8150SS	Ultegra 8150F	Ultegra 8170	Alloy 50-34	Ultegra 8100 11-34	Ultegra 8170	Deda Superbox / Deda Zero	Fulcrum Racing R400DB / Mavic Ksyrium	Vittoria Zaffiro Pro 700*28	San Marco Shortfil	Carbon
VO4434 Shimano 105 Di2 2x12	Road Carbon monocoque custom Olmo	Carbon monocoque custom Olmo	Shimano 105 7150	Shimano 105 7150	Shimano 105 7170	Alloy 50-34	Shimano 7100 11-34	Shimano 105 7170	Deda Superbox / Deda Zero	Fulcrum Racing R900DB / Mavic Aksium	Vittoria Zaffiro Pro 700*28	San Marco Shortfil	Carbon
VO4432 Shimano 105 2x12	Road Carbon monocoque custom Olmo	Carbon monocoque custom Olmo	Shimano 105 7100SS	Shimano 105 7100F	Shimano 105 7120	Alloy 50-34	Shimano 7100 11-34	Shimano 105 7120	Deda Superbox / Deda Zero	Fulcrum Racing R900DB / Mavic Aksium	Vittoria Zaffiro Pro 700*28	San Marco Shortfil	Carbon
VO4430 Shimano 105 2x11	Road Carbon monocoque custom Olmo	Carbon monocoque custom Olmo	Shimano 105 7000SS	Shimano 105 7000F	Shimano 105 7020	Alloy 50-34	Shimano 7000 11-30	Shimano 105 7020	Deda Superbox / Deda Zero	Fulcrum Racing R900DB / Mavic Aksium	Vittoria Rubino Pro 700*28	San Marco Shortfil	Carbon

GIALLO OCRA C020

COLORS

BLU OPACO C006

ROSSO SMALTO C007

CHOOSE
YOUR
COLORS



COLOR CONFIGURATOR

OPTIONAL

Batteria Polini Evo extender 250Wh

Batteria Portapower integrata 630Wh

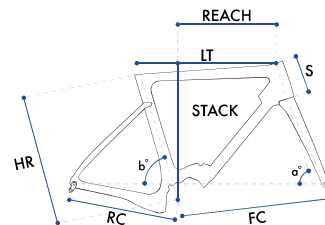

SIZE	470	500	530	560	590
HR	470	500	530	560	590
LT	515	537	555	577	600
RC	420	420	420	420	420
FC	576,4	586,7	592,6	606,9	621,3
a°	72,25°	72,50°	72,75°	73°	73,56°
b°	75,5°	74,5°	73,5°	73°	72,75°
S	120	130	150	165	180
REACH	380	389,4	391,4	403,4	418,7
STACK	522	532,3	552,3	567,5	583,8

MOTORE
ENGINE
MOTEUR
MOTOR

Polini EP3+ Evo

BATTERIA
BATTERY
BATTERIE
BATERÍA

Polini Evo 500Wh

E-BRO 2.0

VO4420 / Shimano Ultegra Di2 2x12



COLORS



COLOR CONFIGURATOR



COLORE IN FOTO
COLOR IN PICTURE

BLU OPACO C006

PESO
WEIGHT
POIDS
PESO

16 kg

E-BRO 2.0

VO4434 / Shimano 105 Di2 2x12



COLORS



COLOR CONFIGURATOR



COLORE IN FOTO
COLOR IN PICTURE

GIALLO OCRA C020

PESO
WEIGHT
POIDS
PESO

16,5 kg

E-BRO 2.0

VO4430 / Shimano 105 2x11



COLORS



COLOR CONFIGURATOR



COLORE IN FOTO
COLOR IN PICTURE

ROSSO SMALTO C007

PESO
WEIGHT
POIDS
PESO

16,6 kg

E-GRIT

	TELAIO FRAME CADRE CUADRO	FORCELLA FORK FOURCHE HORQUILLA	CAMBIO GEARS ARRIER DER. CAMBIO POST.	DERAGL. DERAILLEUR AVANT DER. CAMBIO ANT.	COMANDI CONTROLS MANETTES. PALANCAS DE CAMBIO	GUARN. CRANKSET PEDALIER BIELA	CASSETTA CASSETTE CASSETTE CASSETTE	FRENI BRAKES FREINS FRENOS	MANUBRIO HANDLEBAR GUIDON MANILLAR	RUOTE WHEELS ROUES RUEDAS	GOMME TYRES PNEUS PNEUMATICOS	SELLA SADDLE SELLE SILLIN	REGGISSELLA SEAT POST TIGE DE SELLE TIJA
VO4636 Shimano Grx 1x12	Road Carbon monocoque custom Olmo	Carbon monocoque custom Olmo	Shimano GRX RX-822GS	-	Shimano GRX RX-610	Alloy 42T	Shimano 7100 11-34	Shimano GRX RX-610	Carbon / Deda Gravel100	Fulcrum R900DB / Mavic Speedcity	Kenda Gabbro 700*40	San Marco Shortfil	Carbon
VO4635 Shimano Grx 2x12	Road Carbon monocoque custom Olmo	Carbon monocoque custom Olmo	Shimano GRX RX-822GS	Shimano GRX RX-820F	Shimano RX-610	Alloy 50-34	Shimano 11-34	Shimano RX-610	Carbon / Deda Gravel100	Fulcrum R900DB / Mavic Speedcity	Kenda Gabbro 700*40	San Marco Shortfil	Carbon
VO4634 Shimano 105 Di2 2x12	Road Carbon monocoque custom Olmo	Carbon monocoque custom Olmo	Shimano 105 7150	Shimano 105 7150	Shimano 105 7170	Alloy 50-34	Shimano 7100 11-34	Shimano 105 7170	Carbon / Deda Gravel100	Fulcrum R900DB / Mavic Speedcity	Kenda Gabbro 700*40	San Marco Shortfil	Carbon
VO4632 Shimano 105 2x12	Road Carbon monocoque custom Olmo	Carbon monocoque custom Olmo	Shimano 105 7100SS	Shimano 105 7100F	Shimano 105 7120	Alloy 50-34	Shimano 7100 11-34	Shimano 105 7120	Carbon / Deda Gravel100	Fulcrum R900DB / Mavic Speedcity	Kenda Gabbro 700*40	San Marco Shortfil	Carbon

COLORS

BLU OPACO C006

MARRONE OPACO C008

CHOOSE
YOUR
COLORS



COLOR CONFIGURATOR

OPTIONAL

Batteria Polini Evo extender 250Wh

Batteria Portapower integrata 630Wh

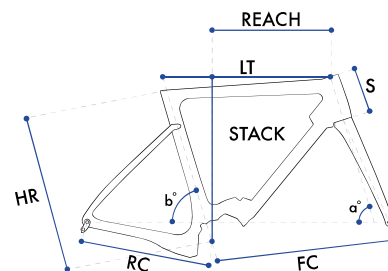

	490	520	540	560	580
HR	450	480	500	520	540
LT	525	535	545	560	575
RC	445	445	445	445	445
FC	598,5	600,6	600,7	605,8	615,7
α°	70,5°	71°	71,5°	72°	72°
β°	74,5°	74°	73,5°	73°	72,5°
S	115	135	145	165	185
REACH	375,5	375,5	370,1	380	384
STACK	538	556	570,6	589	606

MOTORE
ENGINE
MOTEUR
MOTOR

Polini EP3+ Evo

BATTERIA
BATTERY
BATERIE
BATERÍA

Polini Evo 500Wh

E-GRIT GRAVEL

VO4635 / Shimano GRX 2X12



COLORS



COLOR CONFIGURATOR



COLORE IN FOTO
COLOR IN PICTURE

MARRONE OPACO C008

PESO
WEIGHT
POIDS
PESO

16,6 kg

E-GRIT GRAVEL

VO4635 / Shimano GRX 2x12



COLORS



COLOR CONFIGURATOR



COLORE IN FOTO
COLOR IN PICTURE

BLU OPACO C006

PESO
WEIGHT
POIDS
PESO

16,6 kg

E-GRIT SPORT

VO4730 / Shimano 105 2x11



OPTIONAL

Batteria Polini Evo extender 250Wh

Batteria Portapower integrata 630Wh

COLORS



COLOR CONFIGURATOR

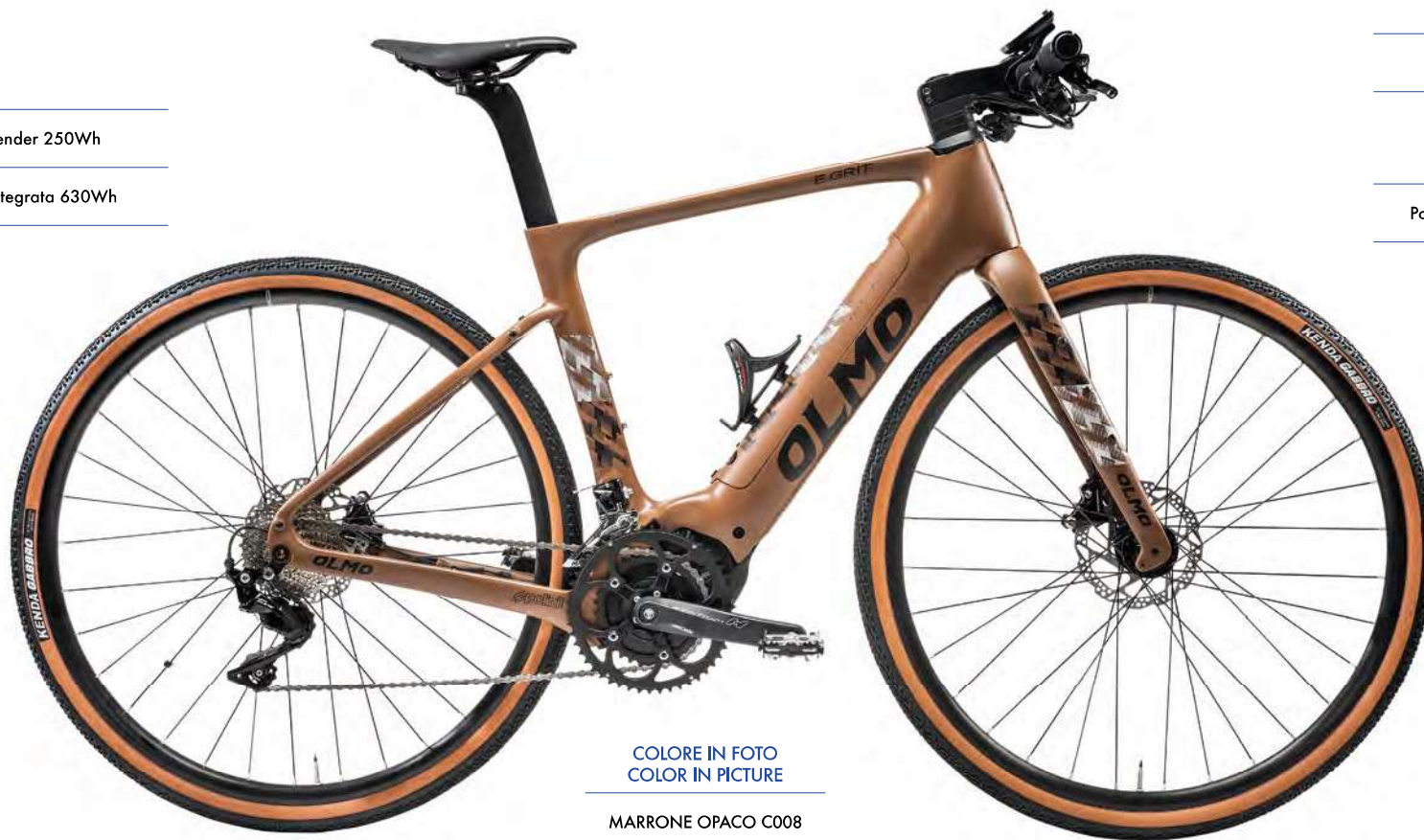

COLORE IN FOTO
COLOR IN PICTURE

MARRONE OPACO C008

MOTORE
ENGINE
MOTEUR
MOTOR

Polini EP3+ Evo

BATTERIA
BATTERY
BATTERIE
BATERÍA

Polini Evo 500Wh

PESO
WEIGHT
POIDS
PESO

17 kg

TELAIO FRAME CADRE CUADRO	FORCELLA FORK FOURCHE HORQUILLA	CAMBIO GEARS ARRIER DER. CAMBIO POST.	DERAGL. DERAILLEUR AVANT DER. CAMBIO ANT.	COMANDI CONTROLS MANETTES. PALANCAS DE CAMBIO	GUARN. CRANKSET PEDALIER BIELA	CASSETTA CASSETTE CASSETTE CASSETTE	FRENI BRAKES FREINS FRENOS	MANUBRIO HANDLEBAR GUIDON MANILLAR	RUOTE WHEELS ROUES RUEDAS	GOMME TYRES PNEUS PNEUMATICOS	SELLA SADDLE SELLE SILLIN	REGGISSELLA SEAT POST TIGE DE SELLE TIJA
------------------------------------	--	---	---	---	---	--	-------------------------------------	---	------------------------------------	--	------------------------------------	---

VO4730
Shimano 105
2x11 Sport

Road Carbon
monocoque
custom Olmo

Carbon mono-
coque custom
Olmo

Shimano 105
7000SS

Shimano 105
7000F

Shimano
RS700

Alloy 50-34

Shimano 7000
11-30

Shimano
RS600

Carbon / Deda
Mud Flat

Fulcrum R900DB /
Mavic Speedcity

Kenda Gabbro
700*40

San Marco
Shortfil

Carbon

SLALOM

TELAIO
FRAME
CADRE
CUADRO

FORCELLA
FORK
FOURCHE
HORQUILLA

CAMBIO
GEARS
ARRIER DER.
CAMBIO
POST.

DERAGL.
DERAILLEUR
AVANT DER.
CAMBIO
ANT.

COMANDI
CONTROLS
MANETTES.
PALANCAS DE
CAMBIO

GUARN.
CRANKSET
PEDALIER
BIELA

CASSETTA
CASSETTE
CASSETTE
CASSETTE

FRENI
BRAKES
FREINS
FRENOS

MANUBRIO
HANDLEBAR
GUIDON
MANILLAR

RUOTE
WHEELS
ROUES
RUEDAS

GOMME
TYRES
PNEUS
PNEUMATICOS

SELLA
SADDLE
SELLE
SILLIN

REGGISSELLA
SEAT POST
TIGE DE SELLE
TIJA

ROAD

VO4520 Ultegra Di2 2x12	Road Alloy custom Olmo	Carbon custom Olmo	Ultegra 8150SS	Ultegra 8150F	Ultegra 8170	Alloy 50-34	Shimano 8100 11-34	Ultegra R8170	Deda Zero	Fulcrum R900DB / Mavic Speedcity	Vittoria Zaffiro Pro 700*32	Selle Italia X3 Boost	Deda Zero
VO4534 Shimano 105 Di2 2x12	Road Alloy custom Olmo	Carbon custom Olmo	Shimano 105 7150	Shimano 105 7150	Shimano 105 7170	Alloy 50-34	Shimano 7100 11-34	Shimano 105 7170	Deda Zero	Fulcrum R900DB / Mavic Speedcity	Vittoria Zaffiro Pro 700*32	Selle Italia X3 Boost	Deda Zero
VO4532 Shimano 105 2x12	Road Alloy custom Olmo	Carbon custom Olmo	Shimano 105 7100SS	Shimano 105 7100F	Shimano 105 7120	Alloy 50-34	Shimano 7100 11-34	Shimano 105 7120	Deda Zero	Fulcrum R900DB / Mavic Speedcity	Vittoria Zaffiro Pro 700*32	Selle Italia X3 Boost	Deda Zero
VO4530 Shimano 105 2x11	Road Alloy custom Olmo	Carbon custom Olmo	Shimano 105 7000SS	Shimano 105 7000F	Shimano 105 7020	Alloy 50-34	Shimano 7000 11-30	Shimano 105 7020	Deda Zero	Fulcrum R900DB / Mavic Speedcity	Vittoria Zaffiro Pro 700*32	Selle Italia X3 Boost	Deda Zero

GRAVEL

VO4836 Shimano Grx 1x12	Road Alloy custom Olmo	Carbon custom Olmo	Shimano GRX RX-822GS	-	Shimano GRX RX-610	Alloy 42T	Shimano 7100 11-34	Shimano GRX RX-610	Deda Zero / Gravel 100	Fulcrum R900DB / Mavic Speedcity	Kenda Gabbro 700*40	Selle Italia X3 Boost	Deda Zero
VO4832 Shimano 105 2x12	Road Alloy custom Olmo	Carbon custom Olmo	Shimano 105 7100SS	Shimano 105 7100F	Shimano 105 7120	Alloy 50-34	Shimano 7100 11-34	Shimano 105 7120	Deda Zero / Gravel 100	Fulcrum R900DB / Mavic Speedcity	Kenda Gabbro 700*40	Selle Italia X3 Boost	Deda Zero
VO4835 Shimano Grx 2x12	Road Alloy custom Olmo	Carbon custom Olmo	Shimano GRX RX-822GS	Shimano GRX RX-820F	Shimano RX-610	Alloy 50-34	Shimano 11-34	Shimano RX-610	Deda Zero / Gravel 100	Fulcrum R900DB / Mavic Speedcity	Kenda Gabbro 700*40	Selle Italia X3 Boost	Deda Zero
VO4825 Shimano Grx 2x10	Road Alloy custom Olmo	Carbon custom Olmo	Shimano GRX RX-400	Shimano GRX RX-400F	Shimano RX-400	Alloy 50-34	Shimano 11-34	Shimano RX-400	Deda Zero / Gravel 100	Fulcrum R900DB / Mavic Speedcity	Kenda Gabbro 700*40	Selle Italia X3 Boost	Deda Zero

COLORS

ARANCIO C030

GRIGIO-BLU C046

OPTIONAL

Batteria Polini Evo extender 250Wh

Batteria Portapower integrata 630Wh

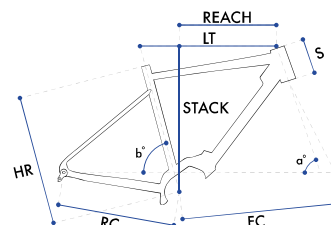

SIZE	490	520	540	560	580
HR	490	520	540	560	580
LT	541	550	559	569	589
RC	460	460	460	460	460
FC	636	636	636	647	668
a°	70,5°	70,5°	71°	71°	71°
b°	75°	74,5°	74°	74°	74°
S	140	140	150	170	190
REACH	406	406	408	412	427
STACK	555	555	567	586	605

MOTORE
ENGINE
MOTEUR
MOTOR

Polini EP3+ Evo

BATTERIA
BATTERY
BATERÍA

Polini Evo 500Wh

SLALOM ROAD

VO4530 / Shimano 105 2x11



COLORS

ARANCIO C030

GRIGIO-BLU C046



PESO
WEIGHT
POIDS
PESO

18,2 kg

SLALOM GRAVEL

VO4835 / Shimano GRX 2x12



COLORS

ARANCIO C030

GRIGIO-BLU C046



PESO
WEIGHT
POIDS
PESO

18,5 kg

SLALOM SPORT

VO4931 / Shimano 105 2x11



OPTIONAL

Batteria Polini Evo extender 250Wh

Batteria Portapower integrata 630Wh

COLORS

ARANCIO C030

GRIGIO-BLU C046



MOTORE
ENGINE
MOTEUR
MOTOR

Polini EP3+ Evo

BATTERIA
BATTERY
BATTERIE
BATERÍA

Polini Evo 500Wh

PESO
WEIGHT
POIDS
PESO

18,6 kg

	TELAIO FRAME CADRE CUADRO	FORCELLA FORK FOURCHE HORQUILLA	CAMBIO GEARS ARRIER DER. CAMBIO POST.	DERAGL. DERAILLEUR AVANT DER. CAMBIO ANT.	COMANDI CONTROLS MANETTES. PALANCAS DE CAMBIO	GUARN. CRANKSET PEDALIER BIELA	CASSETTA CASSETTE CASSETTE CASSETTE	FRENI BRAKES FREINS FRENOS	MANUBRIO HANDLEBAR GUIDON MANILLAR	RUOTE WHEELS ROUES RUEDAS	GOMME TYRES PNEUS PNEUMATICOS	SELLA SADDLE SELLE SILLIN	REGGISELLA SEAT POST TIGE DE SELLE TIJA
VO4931 Shimano 105 2x11	Road Alloy custom Olmo	Carbon custom Olmo	Shimano 105 7000SS	Shimano 105 7000F	Shimano RS700	Alloy 50-34	Shimano 7000 11-30	Shimano RS600	Deda Zero Flat	Fulcrum R900DB / Mavic Speedcity	Kenda Gabbro 700*40	Selle Italia X3 Boost	Deda Zero
VO4961 Shimano Tiagra 2x10	Road Alloy custom Olmo	Carbon custom Olmo	Tiagra 4700SS	Tiagra 4700F	Tiagra 4700 Flat	Alloy 50-34	Shimano 11-34	Shimano RS600	Deda Zero Flat	Fulcrum R900DB / Mavic Speedcity	Kenda Gabbro 700*40	Selle Italia X3 Boost	Deda Zero
VO4951 Shimano Deore 1x11	Road Alloy custom Olmo	Carbon custom Olmo	Shimano Deore M5100	-	Shimano Deore	Alloy 42T	Shimano 11-51	Shimano RS600	Deda Zero Flat	Fulcrum R900DB / Mavic Speedcity	Kenda Gabbro 700*40	Selle Italia X3 Boost	Deda Zero
VO4971 Sram Sx 1x12	Road Alloy custom Olmo	Carbon custom Olmo	Sram Sx	-	Sram Sx Trigger	Alloy 42T	Sram 11-50	Shimano RS600	Deda Zero Flat	Fulcrum R900DB / Mavic Speedcity	Kenda Gabbro 700*40	Selle Italia X3 Boost	Deda Zero





RAPIDA 2.0

VO4134 / Shimano 105 Di2 2x12



OPTIONAL

Batteria Extender 252WH

TURCHESE C019

COLORS

ARANCIO C030

MAGENTA C002



MOTORE
ENGINE
MOTEUR
MOTOR

FSA HM1.0

BATTERIA
BATTERY
BATTERIE
BATERÍA

FSA 252Wh

PESO
WEIGHT
POIDS
PESO

12,8 kg

	TELAIO FRAME CADRE CUADRO	FORCELLA FORK FOURCHE HORQUILLA	CAMBIO GEARS ARRIER DER. CAMBIO POST.	DERAGL. DERAILLEUR AVANT DER. CAMBIO ANT.	COMANDI CONTROLS MANETTES. PALANCAS DE CAMBIO	GUARN. CRANKSET PEDALIER BIELA	CASSETTA CASSETTE CASSETTE CASSETTE	FRENI BRAKES FREINS FRENOS	MANUBRIO HANDLEBAR GUIDON MANILLAR	RUOTE WHEELS ROUES RUEDAS	GOMME TYRES PNEUS PNEUMATICOS	SELLA SADDLE SELLE SILLIN	REGGISELLA SEAT POST TIGE DE SELLE TIJA
VO4120 Ultegra Di2 2x12	Monoscocca carbon Olmo	Carbon monocoque custom Olmo	Ultegra 8150SS	Ultegra 8150F	Ultegra 8170	Ultegra 8100 34-50	Shimano 8100 11-34	Ultegra R8170	Deda Zero	FSA Team 30	Vittoria Zaffiro Pro 700*28	San Marco Shortfit	Carbon
VO4134 Shimano 105 Di2 2x12	Monoscocca carbon Olmo	Carbon monocoque custom Olmo	Shimano 105 7150SS	Shimano 105 7150F	Shimano 105 7170	Shimano 105 7100 50-34	Shimano 7100 11-34	Shimano 105 R7170	Deda Zero	FSA Team 30	Vittoria Zaffiro Pro 700*28	San Marco Shortfit	Carbon
VO4132 Shimano 105 2x12	Monoscocca carbon Olmo	Carbon monocoque custom Olmo	Shimano 105 7100SS	Shimano 105 7100F	Shimano 105 7120	Shimano 105 7100 50-34	Shimano 7100 11-34	Shimano R7120	Deda Zero	FSA Team 30	Vittoria Zaffiro Pro 700*28	Selle Italia X3 Boost	Carbon

RAPIDA 2.0 SPORT

VO4230 / Shimano 105 2x11

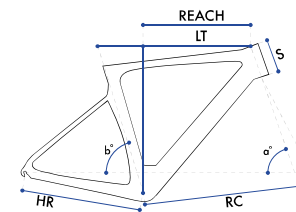

SIZE	490	520	540	560
HR	461	478	495	513
LT	529	535	556	569
RC	415	415	415	415
FC	592	585	591	598
a°	71°	72°	72,5°	73°
b°	73,6°	74°	73,6°	73,3°
S	115	130	150	170
REACH	379	383	388	393
STACK	511	531	551	572



PESO
WEIGHT
POIDS
PESO

13,9 kg
c/pedali

TELAIO FRAME CADRE CUADRO	FORCELLA FORK FOURCHE HORQUILLA	CAMBIO GEARS ARRIER DER. CAMBIO POST.	DERAGL. DERAILLEUR AVANT DER. CAMBIO ANT.	COMANDI CONTROLS MANETTES. PALANCAS DE CAMBIO	GUARN. CRANKSET PEDALIER BIELA	CASSETTA CASSETTE CASSETTE CASSETTE	FRENI BRAKES FREINS FRENOS	MANUBRIO HANDLEBAR GUIDON MANILLAR	RUOTE WHEELS ROUES RUEDAS	GOMME TYRES PNEUS PNEUMATICOS	SELLA SADDLE SELLE SILLIN	REGGISELLA SEAT POST TIGE DE SELLE TIJA
------------------------------------	--	---	---	---	---	--	-------------------------------------	---	------------------------------------	--	------------------------------------	--

VO4230
Shimano 105
2x11

Monoscocca
carbon

Monoscocca
carbon

Shimano
105 7000

Shimano
105 7000F

Shimano
RS700 Flat

Mov 50-34

Shimano
7000 11-30

Shimano
RS600

Deda Zero /
Alloy Flat

FSA Team 30

Vittoria Zaffiro
Pro 700*28

Selle Italia X3
Boost

Carbon

VO4260
Shimano Tiagra
2x10

Monoscocca
carbon

Monoscocca
carbon

Shimano
Tiagra 4700

Shimano Tia-
gra 4700F

Shimano SL-
4700 Flat

Mov 50-34

Shimano 11-34

Shimano
RS600

Deda Zero /
Alloy Flat

FSA Team 30

Vittoria Zaffiro
Pro 700*28

Selle Italia X3
Boost

Carbon

IT. Dall'unione delle tecnologie utilizzate dal gruppo MDE and Montana/Olmo, abbiamo creato la nuovissima OLMO E.KOLT dotata di un evoluto sistema di sospensione virtual pivot.

FR. Grâce à la combinaison des technologies utilisées par le groupe Montana / Olmo et MDE, nous avons créé le tout nouveau OLMO E.Kolt équipé d'un système de suspension avancé à pivot virtuel.

EN. Montana/Olmo group and MDE joined forces to create a groundbreaking e-bike with an advanced virtual pivot suspension system: OLMO E.Kolt.

ES. Gracias a la combinación de las tecnologías utilizadas por el grupo Montana/Olmo y MDE, hemos creado el nuevo E.KOLT equipado con un avanzado sistema de suspensión de pivote virtual.

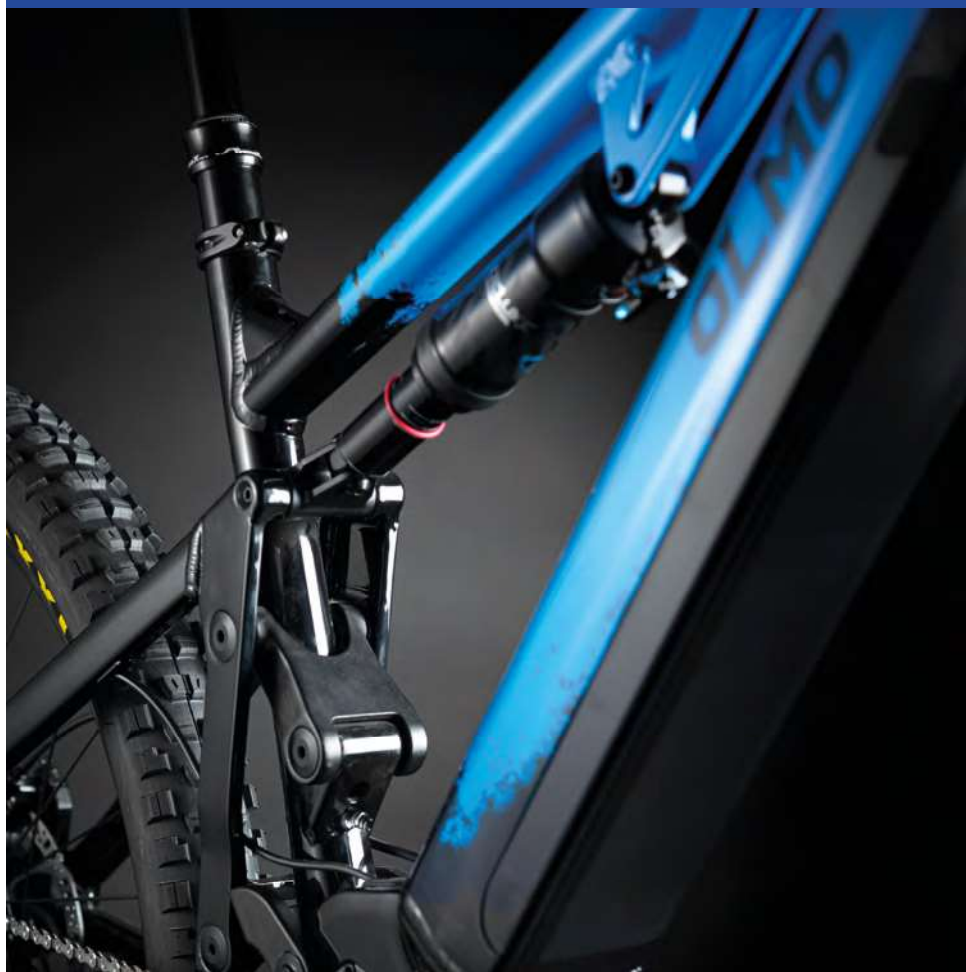

E.KOLT

IT. Il sistema di sospensione ha il perno principale della biella bassa integrato, sviluppa un concetto innovativo per una migliore integrazione con l'unità di trasmissione unificando il perno principale del braccio inferiore con uno dei supporti del motore. Infatti l'unità motore diventa una parte strutturale delle sospensioni posteriori permettendoci di ottenere maggiore spazio per il forcellone posteriore, risparmiare peso e ottenere un notevole aumento di rigidità. Questo ha anche permesso di assicurare un migliore posizionamento del centro istantaneo di rotazione per calibrare il comportamento della sospensione anche in considerazione della spinta aggiuntiva data dall'unità motrice.

Grazie al punto di partenza della curva Anti-Squat risulterà un eccellente comportamento di pedalata. Gli altri fulcri della sospensione hanno perni da 15mm e utilizzano cuscinetti Enduro Bearings.

Il sistema ha una curva di compressione progressiva con un intervallo compreso tra 2,9 e 2,3, in questo modo potrà essere utilizzato sia con ammortizzatori ad aria che a molla. La curva anti-rise rimane al di sotto del 100% dalla posizione di Sag alla fine della corsa, per un effetto neutro sulle forze frenanti. L'ammortizzatore è posto subito sotto e parallelamente al tubo orizzontale a vantaggio della compattezza del telaio, della quota di standover e dello spazio a disposizione all'interno del triangolo principale per poter alloggiare una borraccia.

Cavi e guaine sono all'interno del telaio e grazie alla serie sterzo la E-Kolt gode di un aspetto molto pulito e ordinato dal manubrio.

L'assistenza alla pedalata sulla E.Kolt è fornita dal motore Polini Ep3+ MX con 90Nm e la batteria da 711Wh/19,6 Ah (celle SAMSUNG 21700), un valore che garantisce ampia percorrenza senza ansia da ricarica. Un motore contraddistinto dal segno + (PLUS) che indica tutte le novità rispetto il precedente, l'attento studio e impegno nella progettazione, sempre alla ricerca di migliori performance.

Leggero, potente e compatto, il motore Polini ha un ingombro laterale tra i più ridotti della categoria. La batteria agli ioni di litio è integrata al telaio, dando un accattivante effetto estetico. Il tubo obliquo, studiato per ridurre l'impatto ottico, è realizzato in alluminio trafilato e perfettamente integrato al motore con un punto di sicurezza per il fissaggio della batteria.

EN. For an overall better integration of the frame with the drive unit, the suspension system develops a main pivot of the lower link integrated with one of the engine supports.

The motor unit becomes a structural part of the rear suspensions, allowing not only to have more space for the rear swingarm, but also to have a lighter and considerably stiffer frame. This allows a better positioning of the instant rotation center (I.C.), calibrating the behavior of the suspension also taking in account the additional thrust of the motor.

The anti-squat curve starting point guarantees an excellent pedaling behavior. The other pivotal suspension points are equipped with 15mm axles and Enduro Bearings.

The system has a progressive compression curve with a range from 2.9 to 2.3, allowing a perfect assembly of both air or coil spring shocks. The anti-rise curve remains under 100% from Sag position to full travel, for a neutral effect on brake forces. The rear shock is assembled in parallel right under the top tube supporting both frame compactness and standover quote, creating also space for bottle cage assembling.

Cables and wires getting inside the head set and passing through the frame give E-Kolt a rather tidy and smart look.

E.Kolt pedal assistance is powered by Polini Ep3+MX system, with a 90Nm motor and a 711Wh/19,6 Ah (SAMSUNG cells 21700) battery to cover anxiety-free long distances. A last-generation motor with the "+" sign (PLUS) to show all the innovations compared to the precedent one, and to underline the never-ending analysis, study and commitment in designing it, always looking for better performances. Light, powerful and compact, Polini motor has one of the most reduced lateral volume in its category.

The lithium-ion battery is integrated into the frame, giving the bike a captivating look. The drawn alloy down tube is specifically designed to reduce the visual impact; it is perfectly integrated with the motor case, featuring also a security system for the battery fixing.



FR. Le système de suspension possède un pivot principal intégré de la bielle inférieure. Il utilise un concept innovant pour une meilleure intégration avec l'unité de transmission.

Le pivot principal du bras inférieur est associé à l'un des supports moteur. En fait, le bloc moteur devient une partie structurelle de la suspension arrière, ce qui nous permet d'obtenir plus d'espace pour le bras oscillant arrière, de gagner du poids et d'obtenir une augmentation significative de la rigidité. Ceci a également permis d'assurer un meilleur positionnement du centre instantané de rotation pour calibrer le comportement de la suspension en tenant compte de la poussée supplémentaire donnée par l'unité d'entraînement.

Grâce au point de départ de la courbe « Anti-Squat », il en résultera un excellent comportement de pédalage. Les autres axes de suspension ont des axes de 15 mm et utilisent des roulements Enduro.

Le système a une courbe de compression progressive avec une plage comprise entre 2,9 et 2,3, il peut donc être utilisé avec des amortisseurs à air et à ressort.

La courbe anti-montée reste inférieure à 100% de la position SAG jusqu'à la fin de la course, pour un effet neutre sur les forces de freinage.

L'amortisseur est placé immédiatement en dessous et parallèlement au tube horizontal ce qui favorise la compacité du châssis, de l'enjambement et de l'espace disponible au sein du triangle principal pour accueillir un bidon.

Les câbles et les gaines sont intégrés au cadre. Grâce sa douille de direction, l'E-Kolt a un aspect très pur et bien ordonné depuis le poste de pilotage.

L'assistance au pédalage sur l'E.Kolt est assurée par le moteur Polini Ep3+MX de 90Nm et la batterie 711Wh/19,6 Ah (cellules SAMSUNG 21700), ce qui garantit une longue distance sans inquiétude pour la recharge. Un moteur caractérisé par le signe + (PLUS) qui indique toutes les innovations par rapport au précédent, l'étude minutieuse et l'engagement envers la conception, toujours à la recherche de meilleures performances. Léger, puissant et compact, le moteur Polini possède l'un des plus petits encombrements latéraux de sa catégorie.

La batterie lithium-ion est intégrée dans le cadre, donnant un effet esthétique attractif. Le tube diagonal, conçu pour réduire l'impact visuel, est en aluminium étiré et parfaitement intégré au moteur avec un système de sécurité pour la fixation de la batterie.

ES. El sistema de suspensión tiene integrado el pivote principal de la biela inferior, desarrolla un concepto innovador para una mejor integración con la unidad de transmisión al unificar el pivote principal del brazo inferior con uno de los soportes del motor.

De hecho, el grupo motor se convierte en una parte estructural de la suspensión trasera permitiéndonos obtener más espacio para el basculante trasero, ahorrar peso y obtener un aumento significativo de la rigidez. Esto también permitió asegurar un mejor posicionamiento del centro de rotación instantáneo para calibrar el comportamiento de la suspensión también en consideración del empuje adicional proporcionado por la unidad de transmisión.

Gracias al punto de inicio de la curva Anti-Squat se obtendrá un excelente comportamiento de pedaleo. Los otros ejes de suspensión tienen ejes de 15 mm y usan rodamientos Enduro Bearings.

El sistema tiene una curva de compresión progresiva con un rango entre 2.9 y 2.3, por lo que puede usarse tanto con amortiguadores de aire como de muelle. La curva anti-elevación se mantiene por debajo del 100% desde la posición Sag hasta el final de la carrera, para un efecto neutral en las fuerzas de frenado.

El amortiguador se coloca inmediatamente debajo y paralelo al tubo horizontal en beneficio de la compacidad del marco, la altura del entrepiso y el espacio disponible dentro del triángulo principal para acomodar una botella.

Los cables y las carcassas están dentro del cuadro y, gracias a la dirección, el E.KOLT tiene un aspecto muy limpio y ordenado desde el manillar.

La asistencia al pedaleo en el E.KOLT la proporciona el motor Polini Ep3 + MX con 90Nm y la batería de 711Wh/19,6 Ah (células SAMSUNG 21700), un valor que garantiza una larga distancia sin recargar la ansiedad. Un motor caracterizado por el signo + (PLUS) que indica todas las novedades respecto al anterior, el estudio cuidadoso y la apuesta por el diseño, buscando siempre las mejores prestaciones. Ligero, potente y compacto, el motor Polini tiene una de las dimensiones laterales más pequeñas de su categoría. La batería de iones de litio está integrada en el marco, dando un atractivo efecto estético. El tubo inferior, diseñado para reducir el impacto óptico, está fabricado en aluminio tréfilado y perfectamente integrado con el motor con un punto de seguridad para la fijación de la batería.



E.KOLT MULLET 29" / 27,5"

	TELAIO FRAME CADRE CUADRO	AMMORT. REAR SHOCK AMORTIC. AMMORT.	FORCELLA FORK FOURCHE HORQUILLA	CAMBIO GEARS ARRIER DER. CAMBIO POST.	COMANDI CONTROLS MANETTES. PALANCA DE CAMBIO	GUARN. CRANKSET PEDALIER BIELA	CASSETTA CASSETTE CASSETTE CASSETTE	FRENI BRAKES FREINS FRENOS	MANUBRIO HANDLEBAR GUIDON MANILLAR	RUOTE WHEELS ROUES RUEDAS	GOMME TYRES PNEUS PNEUMATICOS	SELLA SADDLE SELLE SILLIN	REGGISELLA SEAT POST TIGE DE SELLE TIJA
VO3325 Sram NX 12v.	MTB Full 27,5"/29" Alloy 6061 Hydroforming custom Olmo esc. 160mm	Formula Mud	Formula Selva C esc 170mm	Sram NX	Sram NX Trigger E-click	32T	Sram 11-50	Formula Cura 4 220/203	Alloy	Miche XMH-30 29"/27,5" 15/110 12/148 / Mavic Crossride	Maxxis Minion 29*2,5 / 27,5**2,60	San Marco GND	Telescopic Switch 100mm w/remote control
VO3315 Sram NX 12v.	MTB Full 27,5"/29" Alloy 6061 Hydroforming custom Olmo esc. 160mm	Rock Shox Deluxe Ultimate	Rock Shox Lyric 15/110 esc. 180mm	Sram NX	Sram NX Trigger E-click	32T	Sram 11-50	Shimano MT501 4 pistoni 203/180	Alloy	Miche XMH-30 29"/27,5" 15/110 12/148 / Mavic Crossride	Maxxis Minion 29*2,5 / 27,5**2,60	San Marco GND	Telescopic w/ remote control
VO3335 Shimano XT 12v.	MTB Full 27,5"/29" Alloy 6061 Hydroforming custom Olmo esc. 160mm	Rock Shox Deluxe Ultimate	Rock Shox Lyric 15/110 esc. 180mm	Shimano XT M8100	Shimano XT M8100	32T	Shimano 7000 / Sunrace 11-50	Shimano MT501 4 pistoni 203/180	Alloy	Miche XMH-30 29"/27,5" 15/110 12/148 / Mavic Crossride	Maxxis Minion 29*2,5 / 27,5**2,60	San Marco GND	Telescopic w/ remote control
VO3312 Sram NX 12v.	MTB Full 27,5"/29" Alloy 6061 Hydroforming custom Olmo esc. 160mm	Rock Shox Deluxe Select	Rock Shox Yari 15/110 esc. 180mm	Sram NX	Sram NX Trigger E-click	32T	Sram 11-50	Shimano MT501 4 pistoni 203/180	Alloy	Miche XMH-30 29"/27,5" 15/110 12/148 / Mavic Crossride	Maxxis Minion 29*2,5 / 27,5**2,60	San Marco GND	Telescopic w/ remote control
VO3330 Shimano XT 12v.	MTB Full 27,5"/29" Alloy 6061 Hydroforming custom Olmo esc. 160mm	Rock Shox Deluxe Select	Rock Shox Yari 15/110 esc. 180mm	Shimano XT M8100	Shimano XT M8100	32T	Shimano 7000 / Sunrace 11-50	Shimano MT501 4 pistoni 203/180	Alloy	Miche XMH-30 29"/27,5" 15/110 12/148 / Mavic Crossride	Maxxis Minion 29*2,5 / 27,5**2,60	San Marco GND	Telescopic w/ remote control
VO3320 Shimano Deore/XT 11v.	MTB Full 27,5"/29" Alloy 6061 Hydroforming custom Olmo esc. 160mm	Rock Shox Deluxe Select	Rock Shox 35 TK 15/110 esc. 160mm	Shimano XT M8000	Shimano Deore M5100	32T	Shimano Deore 11-51	Tektro M745 / Promax 4 pisto- ni 203/180	Alloy	Mov 29"/27,5" 15/110 12/148	Maxxis Minion 29*2,5 / 27,5**2,60	San Marco GND	Telescopic w/ remote control

COLORS

NERO-BLU C096

NERO-ARANCIO C930

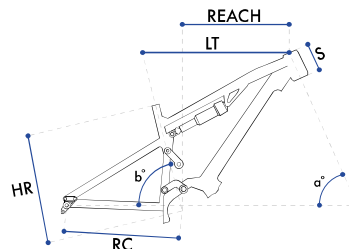

SIZE 400 440 480

HR	400	440	480
LT	575,5	601,3	626,4
RC	455,3	455,3	455,3
a°	65,5°	65,5°	65,5°
b°	75,5°	75,5°	75,5°
S	110	110	130
REACH	416,1	441,8	462

MOTORE
ENGINE
MOTEUR
MOTOR

Polini EP3+ MX
90Nm

BATTERIA
BATTERY
BATTERIE
BATERÍA

Portapower
711Wh

E.KOLT MULLET 29" / 27,5"

VO3325 / Sram NX 12v.



OPTIONAL

disponibile con ruote da 29" / available with 29" wheels

COLORS

NERO-BLU C096

NERO-ARANCIO C930



PESO
WEIGHT
POIDS
PESO

24,9 kg

E.KOLT MULLET 29" / 27,5"

VO3335 / Shimano XT 12v.



OPTIONAL disponibile con ruote da 29" / available with 29" wheels

COLORS

NERO-BLU C096

NERO-ARANCIO C930



PESO
WEIGHT
POIDS
PESO

24,6 kg

E.KOLT MULLET 29" / 27,5"

VO3320 / Shimano Deore-XT 11v.



OPTIONAL disponibile con ruote da 29" / available with 29" wheels

COLORS

NERO-BLU C096

NERO-ARANCIO C930



PESO
WEIGHT
POIDS
PESO

25,3 kg



L.Caramellino: 1° classificato al campionato Italiano E-Mtb Enduro FMI - Luglio 2023



E-VAG 29"

VO3415 / Sram NX 12v.



COLORS

NERO-ROSSO C097

NERO-GRIGIO PERLA C094

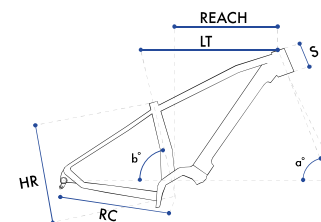

SIZE	425	475	525
HR	425	475	525
LT	570,2	585,6	605,4
RC	470	470	470
a°	68°	68°	68°
b°	74°	74°	74°
S	120	130	140
REACH	407,3	424,6	441,9

MOTORE
ENGINE
MOTEUR
MOTOR

Polini EP3+ MX
90Nm

BATTERIA
BATTERY
BATTERIE
BATERÍA

Lithium Battery
711Wh

PESO
WEIGHT
POIDS
PESO

23 kg

TELAIO
FRAME
CADRE
CUADRO

FORCELLA
FORK
FOURCHE
HORQUILLA

CAMBIO
GEARS
ARRIER DER.
CAMBIO POST.

COMANDI
CONTROLS
MANETTES.
PALANCAS DE
CAMBIO

GUARN.
CRANKSET
PEDALIER
BIELA

CASSETTA
CASSETTE
CASSETTE
CASSETTE

FRENI
BRAKES
FREINS
FRENOS

MANUBRIO
HANDLEBAR
GUIDON
MANILLAR

RUOTE
WHEELS
ROUES
RUEDAS

GOMME
TYRES
PNEUS
PNEUMATICOS

SELLA
SADDLE
SELLE
SILLIN

REGGISELLA
SEAT POST
TIGE DE SELLE
TIJA

VO3415
Sram NX 12v.

MTB Front 29"
Alloy custom
Olmo

Rock Shox Judy
15/110 esc.
100mm

Sram NX

Sram NX Trigger 32T

Sram 11-50

Tektro M745 /
Promax 4 pistoni
203/180

Alloy

Mov 29"
15/110
12/148

Kenda 29"*40

Selle Italia S5
Flow

Telescopic w/
remote control

VO3425
Shimano XT
12v.

MTB Front 29"
Alloy custom
Olmo

Rock Shox Judy
15/110 esc.
100mm

Shimano XT
M8100

Shimano XT
M8100 32T

Shimano 7000 /
Sunrace 11-50

Tektro M745 /
Promax 4 pistoni
203/180

Alloy

Mov 29"
15/110
12/148

Kenda 29"*40

Selle Italia S5
Flow

Telescopic w/
remote control

E-VAG 29"

VO3420 / Shimano Deore 11v.



COLORS

NERO-ROSSO C097

NERO-GRIGIO PERLA C094

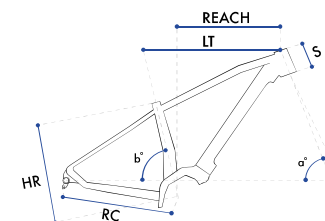

SIZE	425	475	525
HR	425	475	525
LT	570,2	585,6	605,4
RC	470	470	470
a°	68°	68°	68°
b°	74°	74°	74°
S	120	130	140
REACH	407,3	424,6	441,9

MOTORE
ENGINE
MOTEUR
MOTOR

Polini EP3+ 75Nm

BATTERIA
BATTERY
BATTERIE
BATERÍA

Portapower
711Wh

PESO
WEIGHT
POIDS
PESO

23,5 kg

TELAIO
FRAME
CADRE
CUADRO

FORCELLA
FORK
FOURCHE
HORQUILLA

CAMBIO
GEARS
ARRIER DER.
CAMBIO POST.

COMANDI
CONTROLS
MANETTES.
PALANCAS DE
CAMBIO

GUARN.
CRANKSET
PEDALIER
BIELA

CASSETTA
CASSETTE
CASSETTE
CASSETTE

FRENI
BRAKES
FREINS
FRENOS

MANUBRIO
HANDLEBAR
GUIDON
MANILLAR

RUOTE
WHEELS
ROUES
RUEDAS

GOMME
TYRES
PNEUS
PNEUMATICOS

SELLA
SADDLE
SELLE
SILLIN

REGGISELLA
SEAT POST
TIGE DE SELLE
TIJA

VO3412
Sram SX 12v.

MTB Front 29"
Alloy custom
Olmo

Suntour XCM RL
/ RST Blaze RL

Sram SX

Sram SX Trigger

32T

Sram 11-50

Shimano M-200
180/160

Alloy

Mov 29"
15/110
12/148

Kenda 29"*40

Selle Italia
X-base

Alloy

VO3420
Shimano
Deore 11v.

MTB Front 29"
Alloy custom
Olmo

Suntour XCM RL
/ RST Blaze RL

Shimano Deore
M5100

Shimano Deore
M5100

32T

Shimano Deore
11-51

Shimano M-200
180/160

Alloy

Mov 29"
15/110
12/148

Kenda 29"*40

Selle Italia
X-base

Alloy

THURAS 29"

VO3612 / Sram SX 12v.

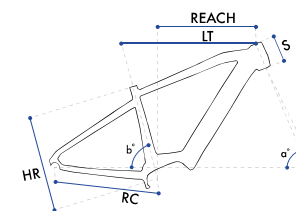

SIZE	400	450	500
HR	400	450	500
LT	599	625	648
RC	480	480	480
a°	67,5°	68°	68,5°
b°	75,5°	75°	74,5°
S	110	120	130
REACH	442	460	474

COLORS

NERO-BLU C096

NERO-MARRONE C998



MOTORE
ENGINE
MOTEUR
MOTOR

Oli Sport Plus 85Nm

BATTERIA
BATTERY
BATTERIE
BATERÍA

Integrated 630Wh

PESO
WEIGHT
POIDS
PESO

25 kg

TELAIO
FRAME
CADRE
CUADRO

FORCELLA
FORK
FOURCHE
HORQUILLA

CAMBIO
GEARS
ARRIER DER.
CAMBIO
POST.

COMANDI
CONTROLS
MANETTES.
PALANCAS
DE CAMBIO

GUARN.
CRANKSET
PEDALIER
BIELA

CASSETTA
CASSETTE
CASSETTE
CASSETTE

FRENI
BRAKES
FREINS
FRENOS

MANUBRIO
HANDLEBAR
GUIDON
MANILLAR

RUOTE
WHEELS
ROUES
RUEDAS

GOMME
TYRES
PNEUS
PNEUMATICOS

SELLA
SADDLE
SELLE
SILLIN

REGGISELLA
SEAT POST
TIGE DE SELLE
TIJA

VO3612
Sram SX 12v.

MTB Front 29" Alloy

Rock Shox Judy
Tk 15/110 esc.
100mm

Sram SX

Sram SX
Trigger

36T

Sram 11-50

Shimano M-200
180/160

Alloy

Mov 29"
15/12

Kenda 29"*2.20

Royal Mach

Alloy

THURAS 29"

VO3640 / Shimano Deore 11v.

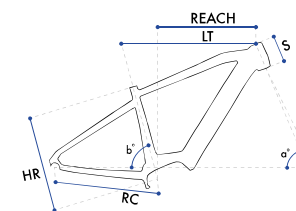

SIZE	400	450	500
HR	400	450	500
LT	599	625	648
RC	480	480	480
a°	67,5°	68°	68,5°
b°	75,5°	75°	74,5°
S	110	120	130
REACH	442	460	474

OPTIONAL

VO3640-1: batteria 630Wh / Battery 630Wh

COLORS

NERO-BLU C096

NERO-MARRONE C998



MOTORE
ENGINE
MOTEUR
MOTOR

Oli Sport Plus 85Nm

BATTERIA
BATTERY
BATTERIE
BATERÍA

Integrated 522Wh

PESO
WEIGHT
POIDS
PESO

25 kg

TELAIO
FRAME
CADRE
CUADRO

FORCELLA
FORK
FOURCHE
HORQUILLA

CAMBIO
GEARS
ARRIER DER.
CAMBIO POST.

COMANDI
CONTROLS
MANETTES.
PALANCA DE
CAMBIO

GUARN.
CRANKSET
PEDALIER
BIELA

CASSETTA
CASSETTE
CASSETTE
CASSETTE

FRENI
BRAKES
FREINS
FRENOS

MANUBRIO
HANDLEBAR
GUIDON
MANILLAR

RUOTE
WHEELS
ROUES
RUEDAS

GOMME
TYRES
PNEUS
PNEUMATICOS

SELLA
SADDLE
SELLE
SILLIN

REGGISSELLA
SEAT POST
TIGE DE SELLE
TIJA

VO3640
Shimano
Deore 11v.

MTB Front 29"
Alloy

Suntour XCM RL /
Rst Blaze RL

Shimano Deore
M5100

Shimano Deore

36T

Shimano
Deore 11-51

Shimano M-200
180/160

Alloy

Mov 29"

Kenda 29"*2.20

Royal Mach

Alloy

E-JET 24"

VO3907 / Shimano Acera 7v.



COLORS

NERO-BLU-ARANCIO C963

NERO-BLU-LIME C913



MOTORE
ENGINE
MOTEUR
MOTOR

Shimano E5000

BATTERIA
BATTERY
BATTERIE
BATERÍA

Shimano BT E-8010
504Wh

PESO
WEIGHT
POIDS
PESO

20,5 kg

TELAIO
FRAME
CADRE
CUADRO

FORCELLA
FORK
FOURCHE
HORQUILLA

CAMBIO
GEARS
ARRIER DER.
CAMBIO POST.

COMANDI
CONTROLS
MANETTES.
PALANCAS DE
CAMBIO

GUARN.
CRANKSET
PEDALIER
BIELA

CASSETTA
CASSETTE
CASSETTE
CASSETTE

FRENI
BRAKES
FREINS
FRENOS

MANUBRIO
HANDLEBAR
GUIDON
MANILLAR

RUOTE
WHEELS
ROUES
RUEDAS

GOMME
TYRES
PNEUS
PNEUMATICOS

REGGISSELLA
SEAT POST
TIGE DE SELLE
TIJA

VO3907
Acera 7v.

Alloy 6061
hydrof.

Suntour XCT HLO

Shimano Acera

Shimano SLM315

Shimano E5000 38T

Shimano 14-34

Disco idraulico

Hi-Ten/Alloy

MTB doppia
camera

24"*2,40

Alloy

E-JET 24"

VO3907 / Shimano Acera 7v.

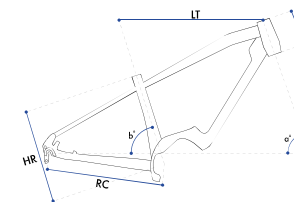

SIZE	350
HR	350
LT	543
RC	435
a°	70.5°
b°	72.5°
S	135

PESO
WEIGHT
POIDS
PESO

20,5 kg

E-XCURSION MAN

VO5920-M / Shimano Deore 11v.



COLORS

BLU OPACO C006

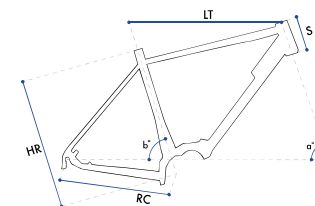

SIZE	530	570
HR	530	570
LT	625	640
RC	454	454
a°	70,5°	70,5°
b°	73°	73°
S	140	150
REACH	433	445

MOTORE
ENGINE
MOTEUR
MOTOR

Polini EP3+ EVO

BATTERIA
BATTERY
BATTERIE
BATERÍA

Polini
500 Wh EVO

PESO
WEIGHT
POIDS
PESO

23,5 Kg

TELAIO
FRAME
CADRE
CUADRO

FORCELLA
FORK
FOURCHE
HORQUILLA

CAMBIO
GEARS
ARRIER DER.
CAMBIO
POST.

COMANDI
CONTROLS
MANETTES.
PALANCS DE
CAMBIO

GUARN.
CRANKSET
PEDALIER
BIELA

CASSETTA
CASSETTE
CASSETTE
CASSETTE

FRENI
BRAKES
FREINS
FRENOS

MANUBRIO
HANDLEBAR
GUIDON
MANILLAR

RUOTE
WHEELS
ROUES
RUEDAS

GOMME
TYRES
PNEUS
PNEUMATI-
COS

SELLA
SADDLE
SELLE
SILLIN

REGGISSELLA
SEAT POST
TIGE DE SELLE
TIJA

VO5920-M
Shimano Deore
11v.

Alloy 6061
hydrof.

RST Neon ML

Shimano Deore
M5100

Deore 11v.

Alloy / 36 T

Deore 11-51

Disco Idrraulico
Shimano

Alloy / Alloy
Regolabile -
Adjustable

Mov 29"

700x40 Reflex
Antiforatura

Royal Rio

Alloy

E-XCURSION LADY

VO5920-L / Shimano Deore 11v.



COLORS

BLU OPACO C006

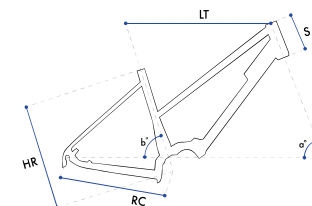

SIZE	460	500
HR	450	500
LT	620	630
RC	454	454
α°	70,5°	70,5°
β°	73°	73°
S	160	160
REACH	422	432

MOTORE
ENGINE
MOTEUR
MOTOR

Polini EP3+ EVO

BATTERIA
BATTERY
BATERIE
BATERÍA

Polini
500 Wh EVO

PESO
WEIGHT
POIDS
PESO

23,5 Kg

TELAIO
FRAME
CADRE
CUADRO

FORCELLA
FORK
FOURCHE
HORQUILLA

CAMBIO
GEARS
ARRIER DER.
CAMBIO
POST.

COMANDI
CONTROLS
MANETTES.
PALANCAS DE
CAMBIO

GUARN.
CRANKSET
PEDALIER
BIELA

CASSETTA
CASSETTE
CASSETTE
CASSETTE

FRENI
BRAKES
FREINS
FRENOS

MANUBRIO
HANDLEBAR
GUIDON
MANILLAR

RUOTE
WHEELS
ROUES
RUEDAS

GOMME
TYRES
PNEUS
PNEUMATI-
COS

SELLA
SADDLE
SELLE
SILLIN

REGGISSELLA
SEAT POST
TIGE DE SELLE
TIJA

VO5920-L
Shimano Deore
11v.

Alloy 6061
hydrof.

RST Neon ML

Shimano Deore
M5100

Deore 11v.

Alloy / 36 T

Deore 11-51

Disco Idrraulico
Shimano

Alloy / Alloy
Regolabile -
Adjustable

Mov 29"

700x40 Reflex
Antiforatura

Royal Rio

Alloy

VICO TRK MAN

VO5808 / Acera 8v.



OPTIONAL

VO5808-2 / Shimano Acera - Motore E6100

VO5805-2 / Shimano Inter 5 - Motore E6100

COLORS

GRIGIO C004

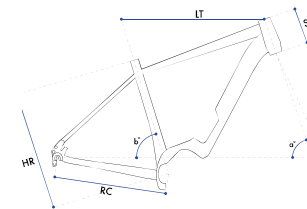

SIZE	490	530	570
HR	490	530	570
LT	580	600	620
α°	70,5°	70,5°	70,5°
b°	73°	73°	73°
RC	465	465	465
S	130	140	150

MOTORE
ENGINE
MOTEUR
MOTOR

Shimano E5000

BATTERIA
BATTERY
BATTERIE
BATERÍA

Shimano BT E-8010
504Wh

PESO
WEIGHT
POIDS
PESO

23,5 kg

TELAIO
FRAME
CADRE
CUADRO

FORCELLA
FORK
FOURCHE
HORQUILLA

CAMBIO
GEARS
ARRIER DER.
CAMBIO POST.

COMANDI
CONTROLS
MANETTES.
PALANCAS DE
CAMBIO

GUARN.
CRANKSET
PEDALIER
BIELA

CASSETTA
CASSETTE
CASSETTE
CASSETTE

FRENI
BRAKES
FREINS
FRENOS

MANUBRIO
HANDLEBAR
GUIDON
MANILLAR

RUOTE
WHEELS
ROUES
RUEDAS

GOMME
TYRES
PNEUS
PNEUMATICOS

SELLA
SADDLE
SELLE
SILLIN

REGGISSELLA
SEAT POST
TIGE DE SELLE
TIJA

VO5808
Acera 8V.

Alloy 6061
hydrof.

RST Neon ML

Shimano Acera

Shimano
SLM315

Shimano E5000
38T

Shimano 11-36

Disco idraulico

Alloy Regolabile

Mov 29"

700x45 reflex
antiforatura

Royal Rio

Alloy

VO5805
Shimano Inter 5

Alloy 6061
hydrof.

RST Neon ML

Shimano Inter 5

Shimano Revo

Shimano E5000
38T

Shimano 27T

Disco idraulico

Alloy Regolabile

Alloy inter 5 disco

700x45 reflex
antiforatura

Royal Rio

Alloy

VICO TRK LADY

VO5708 / Shimano Acera 8v.



OPTIONAL

VO5705-2 / Shimano Inter 5 - Motore E6100

VO5708-2 / Shimano Acera - Motore E6100

COLORS

GRIGIO C004

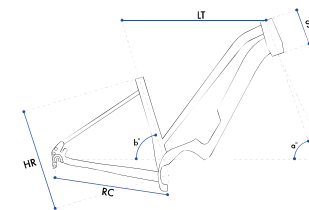

SIZE	420	460	500
HR	420	460	500
LT	575	595	605
α°	70,5°	70,5°	70,5°
β°	73°	73°	73°
RC	465	465	465
S	150	160	170

MOTORE
ENGINE
MOTEUR
MOTOR

Shimano E5000

BATTERIA
BATTERY
BATTERIE
BATERÍA

Shimano BT E-8010
504Wh

PESO
WEIGHT
POIDS
PESO

23,5 kg

TELAIO
FRAME
CADRE
CUADRO

FORCELLA
FORK
FOURCHE
HORQUILLA

CAMBIO
GEARS
ARRIER DER.
CAMBIO POST.

COMANDI
CONTROLS
MANETTES,
PALANCA DE
CAMBIO

GUARN.
CRANKSET
PEDALIER
BIELA

CASSETTA
CASSETTE
CASSETTE
CASSETTE

FRENI
BRAKES
FREINS
FRENOS

MANUBRIO
HANDLEBAR
GUIDON
MANILLAR

RUOTE
WHEELS
ROUES
RUEDAS

GOMME
TYRES
PNEUS
PNEUMATICOS

SELLA
SADDLE
SELLE
SILLIN

REGGISELLA
SEAT POST
TIGE DE SELLE
TIJA

VO5705
Shimano Inter 5

Alloy 6061
hydrof.

RST Neon ML

Shimano Inter 5

Shimano Revo

Shimano E5000
38T

Shimano 27T

Disco idraulico

Alloy Regolabile

Alloy Inter 5
Disco

700x45 reflex
antiforatura

Royal Rio

Alloy

VO5708
Acera 8v.

Alloy 6061
hydrof.

RST Neon ML

Shimano Acera

Shimano SLM315

Shimano E5000
38T

Shimano 11-36

Disco idraulico

Alloy Regolabile

Mov 29"

700x45 reflex
antiforatura

Royal Rio

Alloy

VICO CITY

VO5608/ Acera 8V.



OPTIONAL

VO5608-2 Shimano Acera - Motore E6100

COLORS

GRIGIO C004

SABBIA C008



MOTORE
ENGINE
MOTEUR
MOTOR

Shimano E5000

BATTERIA
BATTERY
BATTERIE
BATERÍA

Shimano BT E-8010
504Wh

PESO
WEIGHT
POIDS
PESO

23,5 kg

TELAIO
FRAME
CADRE
CUADRO

FORCELLA
FORK
FOURCHE
HORQUILLA

CAMBIO
GEARS
ARRIER DER.
CAMBIO POST.

COMANDI
CONTROLS
MANETTES.
PALANCAS DE
CAMBIO

GUARN.
CRANKSET
PEDALIER
BIELA

CASSETTA
CASSETTE
CASSETTE
CASSETTE

FRENI
BRAKES
FREINS
FRENOS

MANUBRIO
HANDLEBAR
GUIDON
MANILLAR

RUOTE
WHEELS
ROUES
RUEDAS

GOMME
TYRES
PNEUS
PNEUMATICOS

SELLA
SADDLE
SELLE
SILLIN

REGGISSELLA
SEAT POST
TIGE DE SELLE
TIJA

VO5608
Acera 8V.

Alloy 6061
hydrof.

RST Neon ML

Shimano Acera

Shimano SLM315

Shimano E5000
38T

Shimano 11-36

Disco idraulico

Alloy Regolabile

Mov 29"

700x45 reflex
antiforatura

Royal Rio

Alloy

VICO CITY

VO5608 / Acera 8V.

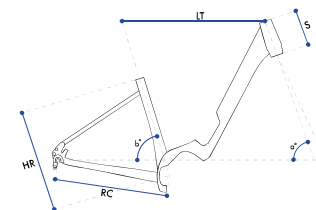

SIZE	420	460	500
HR	420	460	500
LT	570	590	610
α°	70,5°	70,5°	70,5°
β°	73°	73°	73°
RC	465	465	465
S	150	160	170



VICO CITY

VO5605 / Shimano Inter 5



OPTIONAL VO5605-2 / Shimano Inter 5 - Motore E6100

COLORS GRIGIO C004

SABBIA C008



MOTORE
ENGINE
MOTEUR
MOTOR

Shimano E5000

BATTERIA
BATTERY
BATTERIE
BATERÍA

Shimano BT E-8010
504Wh

PESO
WEIGHT
POIDS
PESO

24,8 kg

TELAIO
FRAME
CADRE
CUADRO

FORCELLA
FORK
FOURCHE
HORQUILLA

CAMBIO
GEARS
ARRIER DER.
CAMBIO POST.

COMANDI
CONTROLS
MANETTES.
PALANCAS DE
CAMBIO

GUARN.
CRANKSET
PEDALIER
BIELA

CASSETTA
CASSETTE
CASSETTE
CASSETTE

FRENI
BRAKES
FREINS
FRENOS

MANUBRIO
HANDLEBAR
GUIDON
MANILLAR

RUOTE
WHEELS
ROUES
RUEDAS

GOMME
TYRES
PNEUS
PNEUMATICOS

SELLA
SADDLE
SELLE
SILLIN

REGGISSELLA
SEAT POST
TIGE DE SELLE
TIJA

VO5605
Shimano Inter 5

Alloy 6061
hydrof.

RST Neon ML

Shimano Inter 5

Shimano Revo

Shimano E5000
38T

Shimano 27T

Disco idraulico

Alloy Regolabile

Alloy Inter 5
Disco

700x45 reflex
antiforatura

Royal Rio

Alloy

VICO CITY

VO5605 / Shimano Inter 5

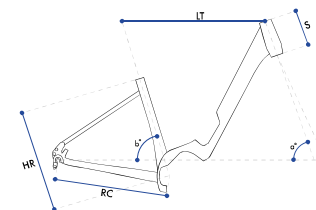

SIZE	420	460	500
HR	420	460	500
LT	570	590	610
A°	70,5°	70,5°	70,5°
B°	73°	73°	73°
RC	465	465	465
S	150	160	170



NAVIGLIO MAN

VO8528 / 28" TY-300 7V. Ctb

SIZE 460-500-540

COLORS

GRIGIO C004

BLU C006



MOTORE
ENGINE
MOTEUR
MOTOR

Erotek

BATTERIA
BATTERY
BATERIE
BATERÍA

integrata 10AH

PESO
WEIGHT
POIDS
PESO

24 kg

TELAIO
FRAME
CADRE
CUADRO

FORCELLA
FORK
FOURCHE
HORQUILLA

CAMBIO
GEARS
ARRIER DER.
CAMBIO POST.

COMANDI
CONTROLS
MANETTES.
PALANCAS DE
CAMBIO

GUARN.
CRANKSET
PEDALIER
BIELA

CASSETTA
CASSETTE
CASSETTE
CASSETTE

FRENI
BRAKES
FREINS
FRENOS

MANUBRIO
HANDLEBAR
GUIDON
MANILLAR

RUOTE
WHEELS
ROUES
RUEDAS

GOMME
TYRES
PNEUS
PNEUMATICOS

REGGISSELLA
SEAT POST
TIGE DE SELLE
TJJA

VO8528

28" TY-300 7V.
Ctb

Alloy 28" man

Alloy rigid

Shimano TY-300

Shimano Revo 7v.

42x170 alloy

Shimano TZ500

Disco meccanico

Alloy Regolabile

Alloy doppia
camera

700x45 reflex
antiforatura

Alloy

NAVIGLIO LADY

VO8428 / 28" TY-300 7V. Ctb

SIZE 440-500

COLORS

VERDE C013

PANNA C001

GRIGIO C004

BLU C006



MOTORE
ENGINE
MOTEUR
MOTOR

Erotek

BATTERIA
BATTERY
BATTERIE
BATERÍA

integrata 10AH

PESO
WEIGHT
PESO
POIDS

24 kg

TELAIO
FRAME
CADRE
CUADRO

FORCELLA
FORK
FOURCHE
HORQUILLA

CAMBIO
GEARS
ARRIER DER.
CAMBIO POST.

COMANDI
CONTROLS
MANETTES.
PALANCAS DE
CAMBIO

GUARN.
CRANKSET
PEDALIER
BIELA

CASSETTA
CASSETTE
CASSETTE
CASSETTE

FRENI
BRAKES
FREINS
FRENOS

MANUBRIO
HANDLEBAR
GUIDON
MANILLAR

RUOTE
WHEELS
ROUES
RUEDAS

GOMME
TYRES
PNEUS
PNEUMATICOS

REGGISSELLA
SEAT POST
TIGE DE SELLE
TJJA

VO8428

28" TY-300 7V.
Ctb

Alloy 28" lady

Alloy rigid

Shimano TY-300

Shimano Revo 7v.

42x170 alloy

Shimano TZ500

Disco meccanico

Alloy Regolabile

Alloy doppia
camera

700x45 reflex
antiforatura

Alloy

NAVIGLIO TRK MAN

VO8700 / 28" TY-300 7V. TRK

SIZE 460-500-540

COLORS

GRIGIO C004

BLU C006



MOTORE
ENGINE
MOTEUR
MOTOR

Erotek

BATTERIA
BATTERY
BATTERIE
BATERÍA

integrata 10AH

PESO
WEIGHT
POIDS
PESO

23 kg

TELAIO
FRAME
CADRE
CUADRO

FORCELLA
FORK
FOURCHE
HORQUILLA

CAMBIO
GEARS
ARRIER DER.
CAMBIO POST.

COMANDI
CONTROLS
MANETTES.
PALANCAS DE
CAMBIO

GUARN.
CRANKSET
PEDALIER
BIELA

CASSETTA
CASSETTE
CASSETTE
CASSETTE

FRENI
BRAKES
FREINS
FRENOS

MANUBRIO
HANDLEBAR
GUIDON
MANILLAR

RUOTE
WHEELS
ROUES
RUEDAS

GOMME
TYRES
PNEUS
PNEUMATICOS

REGGISSELLA
SEAT POST
TIGE DE SELLE
TJJA

VO8700

28" TY-300 7V.
TRK

Alloy trk 28" man

RST Neon ML

Shimano TY-300

Shimano Revo 7v.

42x170 alloy

Shimano TZ500

Disco meccanico

Alloy Regolabile

Alloy doppia
camera

700x45 reflex
antiforatura

Alloy

NAVIGLIO TRK LADY

VO8600 / 28" TY-300 7V. TRK

SIZE 440-500

COLORS

VERDE C013

PANNA C001

GRIGIO C004

BLU C006



MOTORE
ENGINE
MOTEUR
MOTOR

Erotek

BATTERIA
BATTERY
BATTERIE
BATERÍA

integrata 10AH

PESO
WEIGHT
PESO
POIDS

23 kg

TELAIO
FRAME
CADRE
CUADRO

FORCELLA
FORK
FOURCHE
HORQUILLA

CAMBIO
GEARS
ARRIER DER.
CAMBIO POST.

COMANDI
CONTROLS
MANETTES.
PALANCAS DE
CAMBIO

GUARN.
CRANKSET
PEDALIER
BIELA

CASSETTA
CASSETTE
CASSETTE
CASSETTE

FRENI
BRAKES
FREINS
FRENOS

MANUBRIO
HANDLEBAR
GUIDON
MANILLAR

RUOTE
WHEELS
ROUES
RUEDAS

GOMME
TYRES
PNEUS
PNEUMATICOS

REGGISSELLA
SEAT POST
TIGE DE SELLE
TJJA

VO8600

28" TY-300 7V.
TRK

Alloy trk 28" lady

RST Neon ML

Shimano TY-300

Shimano Revo 7v.

42x170 alloy

Shimano TZ500

Disco meccanico

Alloy Regolabile

Alloy doppia
camera

700x45 reflex
antiforatura

Alloy

NAVIGLIO MONOTRAVE

VO8328 / 28" TY-300 7V. Ctb

SIZE 440-500

COLORS

VERDE C013

PANNA C001

GRIGIO C004

BLU C006



MOTORE
ENGINE
MOTEUR
MOTOR

Erotek

BATTERIA
BATTERY
BATERIE
BATERÍA

integrata 10AH

PESO
WEIGHT
POIDS
PESO

24 kg

TELAIO
FRAME
CADRE
CUADRO

FORCELLA
FORK
FOURCHE
HORQUILLA

CAMBIO
GEARS
ARRIER DER.
CAMBIO POST.

COMANDI
CONTROLS
MANETTES.
PALANCAS DE
CAMBIO

GUARN.
CRANKSET
PEDALIER
BIELA

CASSETTA
CASSETTE
CASSETTE
CASSETTE

FRENI
BRAKES
FREINS
FRENOS

MANUBRIO
HANDLEBAR
GUIDON
MANILLAR

RUOTE
WHEELS
ROUES
RUEDAS

GOMME
TYRES
PNEUS
PNEUMATICOS

REGGISSELLA
SEAT POST
TIGE DE SELLE
TJJA

VO8328
28" TY-300 7V.
Ctb

Alloy monotrave
28"

Alloy rigid

Shimano TY-300

Shimano Revo 7v.

42x170 alloy

Shimano TZ500

Disco meccanico

Alloy Regolabile

Alloy doppia
camera

700x45 reflex
antiforatura

Alloy

NAVIGLIO MONOTRAVE

VO8328 / 28" TY-300 7V. Ctb

SIZE 440-500



LEVANTE MAN LUSO

TO5406-1 / 28" Ty-300 6v.

SIZE 490-540

COLORS

NERO C009



MOTORE
ENGINE
MOTEUR
MOTOR

Promovec

BATTERIA
BATTERY
BATERIE
BATERÍA

Promovec al
portapacco
560Wh

PESO
WEIGHT
POIDS
PESO

24,1 kg

TELAIO
FRAME
CADRE
CUADRO

FORCELLA
FORK
FOURCHE
HORQUILLA

CAMBIO
GEARS
ARRIER DER.
CAMBIO POST.

COMANDI
CONTROLS
MANETTES.
PALANCAS DE
CAMBIO

GUARN.
CRANKSET
PEDALIER
BIELA

CASSETTA
CASSETTE
CASSETTE
CASSETTE

FRENI
BRAKES
FREINS
FRENOS

MANUBRIO
HANDLEBAR
GUIDON
MANILLAR

RUOTE
WHEELS
ROUES
RUEDAS

GOMME
TYRES
PNEUS
PNEUMATICOS

REGGISELLA
SEAT POST
TIGE DE SELLE
TIJA

TO5406-1
28" Man Ty-300
6v.

Alloy 28"

Ch-141 Ams

Shimano TY-300

Shimano Revo

42x170 alloy

Shimano TZ500

V-brake alloy

Alloy / Alloy Regolabile -
Adjustable

Alloy doppia cam-
era / Dual chamber
Alloy 28"

700x40 reflex
antiforatura

Alloy

LEVANTE LADY 28" LUSO

TO5306-1 / 28" Ty-300 6v.

SIZE 460-500

COLORS

BIANCO C003

NERO C009



MOTORE
ENGINE
MOTEUR
MOTOR

Promovec

BATTERIA
BATTERY
BATTERIE
BATERÍA

Promovec al
portapacco
560Wh

PESO
WEIGHT
POIDS
PESO

24,4 kg

TELAIO
FRAME
CADRE
CUADRO

FORCELLA
FORK
FOURCHE
HORQUILLA

CAMBIO
GEARS
ARRIER DER.
CAMBIO POST.

COMANDI
CONTROLS
MANETTES.
PALANCAS DE
CAMBIO

GUARN.
CRANKSET
PEDALIER
BIELA

CASSETTA
CASSETTE
CASSETTE
CASSETTE

FRENI
BRAKES
FREINS
FRENOS

MANUBRIO
HANDLEBAR
GUIDON
MANILLAR

RUOTE
WHEELS
ROUES
RUEDAS

GOMME
TYRES
PNEUS
PNEUMATICOS

REGGISELLA
SEAT POST
TIGE DE SELLE
TIJA

TO5306-1
28" Ty-300 6v.

Alloy
monotrave 28"

Ch-141 Ams

Shimano TY-300

Shimano Revo

42x170 alloy

Shimano TZ500

V-brake alloy

Alloy / Alloy Regolabile -
Adjustable

Alloy doppia cam-
era / Dual chamber
Alloy 28"

700x40 reflex
antiforatura

Alloy

LEVANTE LADY 26" LUSO

TO5206-1 / 26" Ty-300 6v.

SIZE 430

COLORS

BIANCO C003

NERO C009



MOTORE
ENGINE
MOTEUR
MOTOR

Promovec

BATTERIA
BATTERY
BATTERIE
BATERÍA

Promovec al
portapacco
560Wh

PESO
WEIGHT
POIDS
PESO

24,5 kg

TELAIO
FRAME
CADRE
CUADRO

FORCELLA
FORK
FOURCHE
HORQUILLA

CAMBIO
GEARS
ARRIER DER.
CAMBIO POST.

COMANDI
CONTROLS
MANETTES.
PALANCA DE
CAMBIO

GUARN.
CRANKSET
PEDALIER
BIELA

CASSETTA
CASSETTE
CASSETTE
CASSETTE

FRENI
BRAKES
FREINS
FRENOS

MANUBRIO
HANDLEBAR
GUIDON
MANILLAR

RUOTE
WHEELS
ROUES
RUEDAS

GOMME
TYRES
PNEUS
PNEUMATICOS

REGGISELLA
SEAT POST
TIGE DE SELLE
TIJA

TO5206-1
26" Ty-300 6v.

Alloy monotrave
26"

Ch-141 Ams

Shimano TY-300

Shimano Revo

42x170 alloy

Shimano TZ500

V-brake alloy

Alloy / Alloy Regolabile -
Adjustable

Alloy doppia camera
/ Dual chamber Alloy
26"

26*1,75 reflex
antiforatura

Alloy

LEVANTE MAN

TO5406 / 28" Ty-300 6v.

SIZE 490-540

COLORS

NERO C009



MOTORE
ENGINE
MOTEUR
MOTOR

Promovec

BATTERIA
BATTERY
BATTERIE
BATERÍA

Promovec al
portapacco
396Wh

PESO
WEIGHT
POIDS
PESO

23,3 kg



TELAIO
FRAME
CADRE
CUADRO

FORCELLA
FORK
FOURCHE
HORQUILLA

CAMBIO
GEARS
ARRIER DER.
CAMBIO POST.

COMANDI
CONTROLS
MANETTES.
PALANCAS DE
CAMBIO

GUARN.
CRANKSET
PEDALIER
BIELA

CASSETTA
CASSETTE
CASSETTE
CASSETTE

FRENI
BRAKES
FREINS
FRENOS

MANUBRIO
HANDLEBAR
GUIDON
MANILLAR

RUOTE
WHEELS
ROUES
RUEDAS

GOMME
TYRES
PNEUS
PNEUMATICOS

REGGISELLA
SEAT POST
TIGE DE SELLE
TIJA

TO5406
28" Man Ty-300 6v.

Alloy 28"

Ch-141 Ams

Shimano TY-300

Shimano Revo

42x170 alloy

Shimano TZ500

V-brake alloy

Alloy / Alloy Regolabile -
Adjustable

Alloy doppia camera
/ Dual chamber Alloy
28"

700x40 reflex
antiforatura

Alloy

LEVANTE LADY 28"

TO5306 / 28" Ty-300 6v.

SIZE 460-500

COLORS

BIANCO C003

NERO C009



MOTORE
ENGINE
MOTEUR
MOTOR

Promovec

BATTERIA
BATTERY
BATERIE
BATERÍA

Promovec al
portapacco
396Wh

PESO
WEIGHT
POIDS
PESO

23,3 kg



TELAIO
FRAME
CADRE
CUADRO

FORCELLA
FORK
FOURCHE
HORQUILLA

CAMBIO
GEARS
ARRIER DER.
CAMBIO POST.

COMANDI
CONTROLS
MANETTES.
PALANCAS DE
CAMBIO

GUARN.
CRANKSET
PEDALIER
BIELA

CASSETTA
CASSETTE
CASSETTE
CASSETTE

FRENI
BRAKES
FREINS
FRENOS

MANUBRIO
HANDLEBAR
GUIDON
MANILLAR

RUOTE
WHEELS
ROUES
RUEDAS

GOMME
TYRES
PNEUS
PNEUMATICOS

REGGISSELLA
SEAT POST
TIGE DE SELLE
TIJA

TO5306
28" Ty-300 6v.

Alloy monotrave
28"

Ch-141 Ams

Shimano TY-300

Shimano Revo

42x170 alloy

Shimano TZ500

V-brake alloy

Alloy / Alloy Regolabile
- Adjustable

Alloy doppia
camera / Dual
chamber Alloy
28"

700x40 reflex
antiforatura

Alloy

LEVANTE LADY 26"

TO5206 / 26" Ty-300 6v.

SIZE 430

COLORS

BIANCO C003

NERO C009



MOTORE
ENGINE
MOTEUR
MOTOR

Promovec

BATTERIA
BATTERY
BATERIE
BATERÍA

Promovec al
portapacco 396Wh

PESO
WEIGHT
POIDS
PESO

23,3 kg

TELAIO
FRAME
CADRE
CUADRO

FORCELLA
FORK
FOURCHE
HORQUILLA

CAMBIO
GEARS
ARRIER DER.
CAMBIO POST.

COMANDI
CONTROLS
MANETTES.
PALANCAS DE
CAMBIO

GUARN.
CRANKSET
PEDALIER
BIELA

CASSETTA
CASSETTE
CASSETTE
CASSETTE

FRENI
BRAKES
FREINS
FRENOS

MANUBRIO
HANDLEBAR
GUIDON
MANILLAR

RUOTE
WHEELS
ROUES
RUEDAS

GOMME
TYRES
PNEUS
PNEUMATICOS

REGGISSELLA
SEAT POST
TIGE DE SELLE
TIJA

TO5206
26" Ty-300 6v.

Alloy monotrave
26"

Ch-141 Ams

Shimano TY-300

Shimano Revo

42x170 alloy

Shimano TZ500

V-brake alloy

Alloy / Alloy Regolabile -
Adjustable

Alloy doppia
camera / Dual
chamber Alloy
26"

26*1,75 reflex
antiforatura

Alloy

PIXEL

TO5506 / Pighevole 20" 6v.

COLORS

GRIGIO C004



MOTORE
ENGINE
MOTEUR
MOTOR

Promovec

BATTERIA
BATTERY
BATTERIE
BATERÍA

Promovec al
portapacco 396Wh

PESO
WEIGHT
POIDS
PESO

20,3 kg

TELAIO
FRAME
CADRE
CUADRO

FORCELLA
FORK
FOURCHE
HORQUILLA

CAMBIO
GEARS
ARRIER DER.
CAMBIO POST.

COMANDI
CONTROLS
MANETTES.
PALANCAS DE
CAMBIO

GUARN.
CRANKSET
PEDALIER
BIELA

CASSETTA
CASSETTE
CASSETTE
CASSETTE

FRENI
BRAKES
FREINS
FRENOS

MANUBRIO
HANDLEBAR
GUIDON
MANILLAR

RUOTE
WHEELS
ROUES
RUEDAS

GOMME
TYRES
PNEUS
PNEUMATICOS

REGGISSELLA
SEAT POST
TIGE DE SELLE
TIJA

TO5506
Pighevole 20" 6v.

Folding Alloy

Ammortizzata /
Suspendue

Shimano TY-21

Shimano Revo 6v.

42x170 alloy

Shimano TZ500

V-brake alloy

Alloy

Alloy doppia
camera / Dual
chamber Alloy
20"

20x1,75

Alloy



QUOTIDIANE

Ride everyday

NAVA MAN DISCO

VO6170-M / 3X8

SIZE 460-490-540

COLORS

GRIGIO-VERDE C413

NERO C009

PESO
WEIGHT
POIDS
PESO

14,3 kg



	TELAIO FRAME CADRE CUADRO	FORCELLA FORK FOURCHE HORQUILLA	CAMBIO GEARS ARRIER DER. CAMBIO POST.	DERAGL. DERAILLEUR AVANT DER. CAMBIO ANT.	COMANDI CONTROLS MANETTES. PALANCAS DE CAMBIO	GUARN. CRANKSET PEDALIER BIELA	CASSETTA CASSETTE CASSETTE CASSETTE	FRENI BRAKES FREINS FRENOS	MANUBRIO HANDLEBAR GUIDON MANILLAR	RUOTE WHEELS ROUES RUEDAS	GOMME TYRES PNEUS PNEUMATICOS	REGGISELLA SEAT POST TIGE DE SELLE TIJA
VO6170-M 3X8 man	Trekking 28" Alloy	RST Neon ML	Shimano Acera	Shimano	Shimano SL M-315	Alu Mov 42/34/24	Shimano HG 31-8	Disc Hydraulic	Alloy Over / Alloy Regolabile - Adjustable	Alloy doppia camera / Dual chamber Alloy 28"	700x40	Alloy
VO6150-M 2x10 man	Trekking 28" Alloy	RST Neon ML	Shimano Deore	Shimano	Shimano Deore	Alu Mov 36/22	Shimano 11-42	Disc Hydraulic	Alloy Over / Alloy Regolabile - Adjustable	Alloy doppia camera / Dual chamber Alloy 28"	700x40	Alloy

NAVA LADY DISCO

VO6170-L / 3X8

SIZE 440-480

COLORS

BIANCO C003

NERO C009

PESO
WEIGHT
POIDS
PESO

14,3 kg



	TELAIO FRAME CADRE CUADRO	FORCELLA FORK FOURCHE HORQUILLA	CAMBIO GEARS ARRIER DER. CAMBIO POST.	DERAGL. DERAILLEUR AVANT DER. CAMBIO ANT.	COMANDI CONTROLS MANETTES. PALANCAS DE CAMBIO	GUARN. CRANKSET PEDALIER BIELA	CASSETTA CASSETTE CASSETTE CASSETTE	FRENI BRAKES FREINS FRENOS	MANUBRIO HANDLEBAR GUIDON MANILLAR	RUOTE WHEELS ROUES RUEDAS	GOMME TYRES PNEUS PNEUMATICOS	REGGISELLA SEAT POST TIGE DE SELLE TIJA
VO6170-L 3x8 lady	Trekking 28" Alloy	RST Neon ML	Shimano Acera	Shimano	Shimano SL M-315	Alu Mov 42/34/24	Shimano HG 31-8	Disc Hydraulic	Alloy Over / Alloy Regolabile - Adjustable	Alloy doppia camera / Dual chamber Alloy 28"	700x40	Alloy
VO6150-L 2x10 lady	Trekking 28" Alloy	RST Neon ML	Shimano Deore	Shimano	Shimano Deore	Alu Mov 36/22	Shimano 11-42	Disc Hydraulic	Alloy Over / Alloy Regolabile - Adjustable	Alloy doppia camera / Dual chamber Alloy 28"	700x40	Alloy

NAVA MAN

VO6190-M / 3x7

SIZE 460-490-540

PESO
WEIGHT
POIDS
PESO

14 kg

OPTIONAL VO6191-M con accessori

COLORS

GRIGIO-VERDE C413

NERO C009



	TELAIO FRAME CADRE CUADRO	FORCELLA FORK FOURCHE HORQUILLA	CAMBIO GEARS ARRIER DER. CAMBIO POST.	DERAGL. DERAILLEUR AVANT DER. CAMBIO ANT.	COMANDI CONTROLS MANETTES. PALANCO DE CAMBIO	GUARN. CRANKSET PEDALIER BIELA	CASSETTA CASSETTE CASSETTE CASSETTE	FRENI BRAKES FREINS FRENOS	MANUBRIO HANDLEBAR GUIDON MANILLAR	RUOTE WHEELS ROUES RUEDAS	GOMME TYRES PNEUS PNEUMATICOS	REGGISSELLA SEAT POST TIGE DE SELLE TIJA
VO6190-M 3X7 Man	Trekking 28" Alloy	CH-141 MLO	Shimano TY-300 / Ty-21	Shimano	Shimano ST EF-500	Alu Mov 42/34/24	Shimano TZ500 / Index 7v.	V-brake Alloy	Alloy Over / Alloy Regolabile - Adjustable	Alloy doppia camera / Dual chamber Alloy 28"	700x40	Alloy

NAVA LADY

VO6190-L / 3x7

SIZE 440-480

PESO
WEIGHT
POIDS
PESO

14 kg

OPTIONAL VO6191-L con accessori

BIANCO C003

COLORS

NERO C009



	TELAJO FRAME CADRE CUADRO	FORCELLA FORK FOURCHE HORQUILLA	CAMBIO GEARS ARRIER DER. CAMBIO POST.	DERAGL. DERAILLEUR AVANT DER. CAMBIO ANT.	COMANDI CONTROLS MANETTES. PALANQUES DE CAMBIO	GUARN. CRANKSET PEDALIER BIELA	CASSETTA CASSETTE CASSETTE CASSETTE	FRENI BRAKES FREINS FRENOS	MANUBRIO HANDLEBAR GUIDON MANILLAR	RUOTE WHEELS ROUES RUEDAS	GOMME TYRES PNEUS PNEUMATICOS	REGGISSELLA SEAT POST TIGE DE SELLE TIJA
VO6190-L 3X7 Lady	Trekking 28" Alloy	CH-141 MLO	Shimano TY-300 / Ty-21	Shimano	Shimano ST EF-500	Alu Mov 42/34/24	Shimano TZ500 / Index 7v.	V-brake Alloy	Alloy Over / Alloy Regolabile - Adjustable	Alloy doppia camera / Dual chamber Alloy 28"	700x40	Alloy

DEMONTE 27,5"

TO6290 / MTB 27,5" 3x7

SIZE 400-450

COLORS

NERO-VERDE C913

ROSSO C007



TELAJO
FRAME
CADRE
CUADRO

FORCELLA
FORK
FOURCHE
HORQUILLA

CAMBIO
GEARS
ARRIER DER.
CAMBIO
POST.

DERAGL.
DERAILLEUR
AVANT DER.
CAMBIO ANT.

COMANDI
CONTROLS
MANETTES.
PALANCAS DE
CAMBIO

GUARN.
CRANKSET
PEDALIER
BIELA

CASSETTA
CASSETTE
CASSETTE
CASSETTE

FRENI
BRAKES
FREINS
FRENOS

MANUBRIO
HANDLEBAR
GUIDON
MANILLAR

RUOTE
WHEELS
ROUES
RUEDAS

GOMME
TYRES
PNEUS
PNEUMATI-
COS

REGGISSELLA
SEAT POST
TIGE DE SELLE
TIJA

TO6290

MTB 27,5" 3x7

MTB 27,5"
Hi-Ten Tig

Ammortizzata /
Suspension

Shimano TY-300
/ Ty-21

Shimano

Sti Galon / Mov

42/34/24x170

Shimano TZ500
/ Index 7v.

Disco meccanico

Hi ten / Alloy
Head

Mov 27,5"

MTB 27,5x2,20

Hi ten

DEMONTE 27,5"

TO6290 / MTB 27,5" 3x7



PESO
WEIGHT
POIDS
PESO

17,7 kg

DEMONTE 24"

TO7621 / MTB 24" 3x6

COLORS

NERO-VERDE C913

ROSSO C007



PESO
WEIGHT
POIDS
PESO

15,8 kg

TELAJO
FRAME
CADRE
CUADRO

FORCELLA
FORK
FOURCHE
HORQUILLA

CAMBIO
GEARS
ARRIER DER.
CAMBIO
POST.

DERAGL.
DERAILLEUR
AVANT DER.
CAMBIO ANT.

COMANDI
CONTROLS
MANETTES.
PALANCA DE
CAMBIO

GUARN.
CRANKSET
PEDALIER
BIELA

CASSETTA
CASSETTE
CASSETTE
CASSETTE

FRENI
BRAKES
FREINS
FRENOS

MANUBRIO
HANDLEBAR
GUIDON
MANILLAR

RUOTE
WHEELS
ROUES
RUEDAS

GOMME
TYRES
PNEUS
PNEUMATI-
COS

REGGISELLA
SEAT POST
TIGE DE SELLE
TIJA

TO7621
MTB 24" 3x6

MTB 24" Hi-ten
Tig

Ammortizzata /
Suspension

Shimano Ty-21

Shimano

Shimano Revo

42/34/24*152

Shimano TZ500
/ Index 6v.

Disco meccanico

Hi ten / Alloy
Head

Alloy 24" nere /
Black

MTB 24x2,40

Hi ten

DEMONTE 20"

TO7706 / MTB 20" 6v.

COLORS

NERO-VERDE C913

ROSSO C007



PESO
WEIGHT
POIDS
PESO

14,2 kg

TELAJO
FRAME
CADRE
CUADRO

FORCELLA
FORK
FOURCHE
HORQUILLA

CAMBIO
GEARS
ARRIER DER.
CAMBIO
POST.

DERAGL.
DERAILLEUR
AVANT DER.
CAMBIO ANT.

COMANDI
CONTROLS
MANETTES.
PALANCAS DE
CAMBIO

GUARN.
CRANKSET
PEDALIER
BIELA

CASSETTA
CASSETTE
CASSETTE
CASSETTE

FRENI
BRAKES
FREINS
FRENOS

MANUBRIO
HANDLEBAR
GUIDON
MANILLAR

RUOTE
WHEELS
ROUES
RUEDAS

GOMME
TYRES
PNEUS
PNEUMATI-
COS

REGGISELLA
SEAT POST
TIGE DE SELLE
TIJA

TO7706
MTB 20" 6v.

MTB 20" Hi
Ten Tig

Ammortizzata /
Suspension

Shimano Ty-21

Shimano

Shimano Revo

42*140

Shimano TZ500
/ Index 6v.

Disco meccanico

Hi ten / Alloy
Head

Alloy 20" nere /
Black

MTB 20x2,40

Hi ten

SENTIERO 26"

TO6221-M / MTB 26" 3x7

SIZE 380-480

PESO
WEIGHT
POIDS
PESO

15,2 kg

COLORS

ARANCIO C030

BLU-LIME C136



TELAJO
FRAME
CADRE
CUADRO

FORCELLA
FORK
FOURCHE
HORQUILLA

CAMBIO
GEARS
ARRIER DER.
CAMBIO
POST.

DERAGL.
DERAILLEUR
AVANT DER.
CAMBIO ANT.

COMANDI
CONTROLS
MANETTES.
PALANCAS DE
CAMBIO

GUARN.
CRANKSET
PEDALIER
BIELA

CASSETTA
CASSETTE
CASSETTE
CASSETTE

FRENI
BRAKES
FREINS
FRENOS

MANUBRIO
HANDLEBAR
GUIDON
MANILLAR

RUOTE
WHEELS
ROUES
RUEDAS

GOMME
TYRES
PNEUS
PNEUMATICOS

REGGISSELLA
SEAT POST
TIGE DE SELLE
TIJA

TO6221-M
MTB 26" 3x7

MTB 26" Hi-
Ten Tig

Ammortizzata /
Suspension

Shimano TY-21

Shimano

Sti Galon / Mov

42/34/24x170

Shimano TZ500
/ Index 7v.

V-brake Alloy

Hi ten / Alloy
Head

Alloy Silver 26"

MTB 26x2,10

Hi ten

SENTIERO 26"

TO6221-M / MTB 26" 3x7



PESO
WEIGHT
POIDS
PESO

15,2 kg

SENTIERO 24"

TO7118-M / MTB 24" 3x6

SIZE 350

COLORS

ARANCIO C030

BLU-LIME C136



PESO
WEIGHT
POIDS
PESO

14,3 kg

TELAJO
FRAME
CADRE
CUADRO

FORCELLA
FORK
FOURCHE
HORQUILLA

CAMBIO
GEARS
ARRIER DER.
CAMBIO
POST.

DERAGL.
DERAILLEUR
AVANT DER.
CAMBIO ANT.

COMANDI
CONTROLS
MANETTES.
PALANCAS DE
CAMBIO

GUARN.
CRANKSET
PEDALIER
BIELA

CASSETTA
CASSETTE
CASSETTE
CASSETTE

FRENI
BRAKES
FREINS
FRENOS

MANUBRIO
HANDLEBAR
GUIDON
MANILLAR

RUOTE
WHEELS
ROUES
RUEDAS

GOMME
TYRES
PNEUS
PNEUMATICOS

REGGISSELLA
SEAT POST
TIGE DE SELLE
TIJA

TO7118-M
MTB 24" 3x6

MTB 24" Hi
Ten Tig

Ammortizzata /
Suspension

Shimano TY-21

Shimano

Shimano Revo

42/34/24x150

Shimano TZ500
/ Index 6v.

V-brake Alloy

Hi ten / Alloy
Head

Alloy Silver 24"

MTB 24x2,10

Hi ten

SENTIERO 20"

TO7206-M / MTB 20" 6v.

SIZE 300

COLORS

ARANCIO C030

BLU-LIME C136



PESO
WEIGHT
POIDS
PESO

12,3 kg

TELAJO
FRAME
CADRE
CUADRO

FORCELLA
FORK
FOURCHE
HORQUILLA

CAMBIO
GEARS
ARRIER DER.
CAMBIO
POST.

DERAGL.
DERAILLEUR
AVANT DER.
CAMBIO ANT.

COMANDI
CONTROLS
MANETTES.
PALANCAS DE
CAMBIO

GUARN.
CRANKSET
PEDALIER
BIELA

CASSETTA
CASSETTE
CASSETTE
CASSETTE

FRENI
BRAKES
FREINS
FRENOS

MANUBRIO
HANDLEBAR
GUIDON
MANILLAR

RUOTE
WHEELS
ROUES
RUEDAS

GOMME
TYRES
PNEUS
PNEUMATICOS

REGGISSELLA
SEAT POST
TIGE DE SELLE
TIJA

TO7206-M
MTB 20" 6v.

MTB 20" Hi
Ten Tig

Ammortizzata /
Suspension

Shimano TY-21

-

Shimano Revo

40x150

Shimano TZ500
/ Index 6v.

V-brake Alloy

Hi ten / Alloy
Head

Alloy Silver 20"

MTB 20x2,10

Hi ten

AVVENTURA 26"

TO6221-L / MTB 26" 3x7

SIZE 380-450

COLORS

BIANCO C003

MAGENTA C002

PESO
WEIGHT
POIDS
PESO

15,2 kg



TELAJO
FRAME
CADRE
CUADRO

FORCELLA
FORK
FOURCHE
HORQUILLA

CAMBIO
GEARS
ARRIER DER.
CAMBIO
POST.

DERAGL.
DERAILLEUR
AVANT DER.
CAMBIO ANT.

COMANDI
CONTROLS
MANETTES.
PALANCAS DE
CAMBIO

GUARN.
CRANKSET
PEDALIER
BIELA

CASSETTA
CASSETTE
CASSETTE
CASSETTE

FRENI
BRAKES
FREINS
FRENOS

MANUBRIO
HANDLEBAR
GUIDON
MANILLAR

RUOTE
WHEELS
ROUES
RUEDAS

GOMME
TYRES
PNEUS
PNEUMATI-
COS

REGGISELLA
SEAT POST
TIGE DE SELLE
TIJA

TO6221-L
MTB 26" 3x7

MTB 26" Hi-Ten
Tig

Ammortizzata /
Suspension

Shimano TY-21

Shimano

Sti Galon / Mov

42/34/24x170

Shimano TZ500
/ Index 7v.

V-brake Alloy

Hi ten / Alloy
Head

Alloy Silver 26"

MTB 26x2,10

Hi ten

AVVENTURA 26"

TO6221-L / MTB 26" 3x7



PESO
WEIGHT
POIDS
PESO

15,2 kg

AVVENTURA 24"

TO7118-L / Mtb 24" 3x6

SIZE 350

COLORS

BIANCO C003

MAGENTA C002



PESO
WEIGHT
POIDS
PESO

14,3 kg

TELAIO
FRAME
CADRE
CUADRO

FORCELLA
FORK
FOURCHE
HORQUILLA

CAMBIO
GEARS
ARRIER DER.
CAMBIO
POST.

DERAGL.
DERAILLEUR
AVANT DER.
CAMBIO ANT.

COMANDI
CONTROLS
MANETTES.
PALANCAS DE
CAMBIO

GUARN.
CRANKSET
PEDALIER
BIELA

CASSETTA
CASSETTE
CASSETTE
CASSETTE

FRENI
BRAKES
FREINS
FRENOS

MANUBRIO
HANDLEBAR
GUIDON
MANILLAR

RUOTE
WHEELS
ROUES
RUEDAS

GOMME
TYRES
PNEUS
PNEUMATI-
COS

REGGISSELLA
SEAT POST
TIGE DE SELLE
TIJA

TO7118-L
MTB 24" 3x6

MTB 24" Hi
Ten Tig

Ammortizzata /
Suspension

Shimano TY-21

Shimano

Shimano Revo

42/34/24x150

Shimano TZ500
/ Index 6v.

V-brake Alloy

Hi ten / Alloy
Head

Alloy Silver 24"

MTB 24x2,10

Hi ten

AVVENTURA 20"

TO7206-L / Mtb 20" 6v.

SIZE 300

COLORS

BIANCO C003

MAGENTA C002



PESO
WEIGHT
POIDS
PESO

12,3 kg

TELAJO
FRAME
CADRE
CUADRO

FORCELLA
FORK
FOURCHE
HORQUILLA

CAMBIO
GEARS
ARRIER DER.
CAMBIO
POST.

DERAGL.
DERAILLEUR
AVANT DER.
CAMBIO ANT.

COMANDI
CONTROLS
MANETTES.
PALANCAS DE
CAMBIO

GUARN.
CRANKSET
PEDALIER
BIELA

CASSETTA
CASSETTE
CASSETTE
CASSETTE

FRENI
BRAKES
FREINS
FRENOS

MANUBRIO
HANDLEBAR
GUIDON
MANILLAR

RUOTE
WHEELS
ROUES
RUEDAS

GOMME
TYRES
PNEUS
PNEUMATI-
COS

REGGISSELLA
SEAT POST
TIGE DE SELLE
TIJA

TO7206-L
MTB 20" 6v.

MTB 20" Hi
Ten Tig

Ammortizzata /
Suspension

Shimano TY-21

-

Shimano Revo

40x150

Shimano TZ500
/ Index 6v.

V-brake Alloy

Hi ten / Alloy
Head

Alloy Silver 20"

MTB 20x2,10

Hi ten

GRAFFITO 20"

TO7300 / Bmx 20"

COLORS

GRIGIO-ROSSO C047

NERO-VERDE C913

PESO
WEIGHT
POIDS
PESO

14,6 kg



TELAIO
FRAME
CADRE
CUADRO

FORCELLA
FORK
FOURCHE
HORQUILLA

GUARN.
CRANKSET
PEDALIER
BIELA

CASSETTA
CASSETTE
CASSETTE
CASSETTE

FRENI
BRAKES
FREINS
FRENOS

MANUBRIO
HANDLEBAR
GUIDON
MANILLAR

RUOTE
WHEELS
ROUES
RUEDAS

GOMME
TYRES
PNEUS
PNEUMATICOS

REGGISSELLA
SEAT POST
TIGE DE SELLE
TIJA

TO7300
Bmx 20"

BMX 20" Hi-Ten

Hi ten

Fauber 44x170

18T

V-brake Alloy

Hi ten / Alloy

Alloy nero rettificato / Black
rectified Alloy 20" 48F

20x1.95

Hi ten

GRAFFITO 20"

TO7300 / Bmx 20"



PESO
WEIGHT
POIDS
PESO

14,6 kg

BORGO MAN

TO6330-M / 3X7 Man

SIZE 490-540

COLORS

NERO C009

GRIGIO C004

PESO
WEIGHT
POIDS
PESO

14,7 kg



TELAJO
FRAME
CADRE
CUADRO

FORCELLA
FORK
FOURCHE
HORQUILLA

CAMBIO
GEARS
ARRIER DER.
CAMBIO
POST.

DERAGL.
DERAILLEUR
AVANT DER.
CAMBIO ANT.

COMANDI
CONTROLS
MANETTES.
PALANCAS DE
CAMBIO

GUARN.
CRANKSET
PEDALIER
BIELA

CASSETTA
CASSETTE
CASSETTE
CASSETTE

FRENI
BRAKES
FREINS
FRENOS

MANUBRIO
HANDLEBAR
GUIDON
MANILLAR

RUOTE
WHEELS
ROUES
RUEDAS

GOMME
TYRES
PNEUS
PNEUMATICOS

REGGISSELLA
SEAT POST
TIGE DE SELLE
TIJA

TO6330-M
3X7 Man

Trekking 28"
Alloy

Hi ten

Shimano TY-300
/ Ty-21

Shimano

Shimano ST
EF-51

Alloy
42/34/24x170

Shimano TZ500
/ Index 7v.

V-brake Alloy

Alloy / Alloy
regolabile /
Adjustable Alloy

Alloy Doppia
Camera / Dual
Chamber Alloy
28"

700x38

Alloy

BORGO LADY

TO6330-L / 3X7 Lady

SIZE 440-480

COLORS

SABBIA C008

GRIGIO C004

PESO
WEIGHT
POIDS
PESO

15,4 kg



TELAIO
FRAME
CADRE
CUADRO

FORCELLA
FORK
FOURCHE
HORQUILLA

CAMBIO
GEARS
ARRIER DER.
CAMBIO
POST.

DERAGL.
DERAILLEUR
AVANT DER.
CAMBIO ANT.

COMANDI
CONTROLS
MANETTES.
PALANCA DE
CAMBIO

GUARN.
CRANKSET
PEDALIER
BIELA

CASSETTA
CASSETTE
CASSETTE
CASSETTE

FRENI
BRAKES
FREINS
FRENOS

MANUBRIO
HANDLEBAR
GUIDON
MANILLAR

RUOTE
WHEELS
ROUES
RUEDAS

GOMME
TYRES
PNEUS
PNEUMATICOS

REGGISSELLA
SEAT POST
TIGE DE SELLE
TIJA

TO6330-L
3X7 Lady

Trekking 28"
Alloy

Hi ten

Shimano TY-300
/ Ty-21

Shimano

Shimano ST
EF-51

Alloy
42/34/24x170

Shimano TZ500
/ Index 7v.

V-brake Alloy

Alloy / Alloy
regolabile /
Adjustable Alloy

Alloy Doppia
Camera / Dual
Chamber Alloy
28"

700x38

Alloy

BORGO MAN

TO6321-M / 3X7 Man

SIZE 490-540

COLORS

NERO C009

GRIGIO C004

PESO
WEIGHT
POIDS
PESO

14,9 kg



TELAJO
FRAME
CADRE
CUADRO

FORCELLA
FORK
FOURCHE
HORQUILLA

CAMBIO
GEARS
ARRIER DER.
CAMBIO
POST.

DERAGL.
DERAILLEUR
AVANT DER.
CAMBIO ANT.

COMANDI
CONTROLS
MANETTES.
PALANCAS DE
CAMBIO

GUARN.
CRANKSET
PEDALIER
BIELA

CASSETTA
CASSETTE
CASSETTE
CASSETTE

FRENI
BRAKES
FREINS
FRENOS

MANUBRIO
HANDLEBAR
GUIDON
MANILLAR

RUOTE
WHEELS
ROUES
RUEDAS

GOMME
TYRES
PNEUS
PNEUMATICOS

REGGISSELLA
SEAT POST
TIGE DE SELLE
TIJA

TO6321-M
3X7 Man

Trekking 28"
Alloy

Hi ten

Shimano TY-300
/ Ty-21

Shimano

Shimano Revo

42/34/24x170

Shimano TZ500
/ Index 7v.

V-brake Alloy

Alloy / Alloy
regolabile / Ad-
justable Alloy

Alloy 28" nero
rettificato / alloy
black rectified
28"

700x38

Alloy

BORGO LADY

TO6321-L / 3X7 Lady

SIZE 440-480

COLORS

SABBIA C008

GRIGIO C004

PESO
WEIGHT
POIDS
PESO

15,7 kg



TELAIO
FRAME
CADRE
CUADRO

FORCELLA
FORK
FOURCHE
HORQUILLA

CAMBIO
GEARS
ARRIER DER.
CAMBIO
POST.

DERAGL.
DERAILLEUR
AVANT DER.
CAMBIO ANT.

COMANDI
CONTROLS
MANETTES.
PALANCAS DE
CAMBIO

GUARN.
CRANKSET
PEDALIER
BIELA

CASSETTA
CASSETTE
CASSETTE
CASSETTE

FRENI
BRAKES
FREINS
FRENOS

MANUBRIO
HANDLEBAR
GUIDON
MANILLAR

RUOTE
WHEELS
ROUES
RUEDAS

GOMME
TYRES
PNEUS
PNEUMATICOS

REGGISSELLA
SEAT POST
TIGE DE SELLE
TUA

TO6321-L
3X7 Lady

Trekking 28"
Alloy

Hi ten

Shimano TY-300
/ Ty-21

Shimano

Shimano Revo

42/34/24x170

Shimano TZ500
/ Index 7v.

V-brake Alloy

Alloy / Alloy regolabile /
Adjustable Alloy

Alloy 28" nero
rettificato /
Alloy black
rectified 28"

700x38

Alloy

BORGO MAN

TO6307-M / 7V. Man

SIZE 490-540

COLORS

NERO C009

GRIGIO C004

PESO
WEIGHT
POIDS
PESO

14,6 kg



TELAJO
FRAME
CADRE
CUADRO

FORCELLA
FORK
FOURCHE
HORQUILLA

CAMBIO
GEARS
ARRIER DER.
CAMBIO POST.

COMANDI
CONTROLS
MANETTES.
PALANCIAS DE
CAMBIO

GUARN.
CRANKSET
PEDALIER
BIELA

CASSETTA
CASSETTE
CASSETTE
CASSETTE

FRENI
BRAKES
FREINS
FRENOS

MANUBRIO
HANDLEBAR
GUIDON
MANILLAR

RUOTE
WHEELS
ROUES
RUEDAS

GOMME
TYRES
PNEUS
PNEUMATICOS

REGGISSELLA
SEAT POST
TIGE DE SELLE
TIJA

TO6307-M
7V. Man

Trekking 28" Alloy

Hi ten

Shimano TY-300 /
Ty-21

Shimano Revo

42x170

Shimano TZ500 /
Index 7v.

V-brake Alloy

Alloy / Alloy rego-
labile / Adjustable
Alloy

Alloy 28" nero
rettificato / alloy
black rectified 28"

700x38

Alloy

BORGO LADY

TO6307-L / 7v. Lady

SIZE 440-480

COLORS

SABBIA C008

GRIGIO C004

PESO
WEIGHT
POIDS
PESO

15,4 kg



TELAJO
FRAME
CADRE
CUADRO

FORCELLA
FORK
FOURCHE
HORQUILLA

CAMBIO
GEARS
ARRIER DER.
CAMBIO POST.

COMANDI
CONTROLS
MANETTES.
PALANCAS DE
CAMBIO

GUARN.
CRANKSET
PEDALIER
BIELA

CASSETTA
CASSETTE
CASSETTE
CASSETTE

FRENI
BRAKES
FREINS
FRENOS

MANUBRIO
HANDLEBAR
GUIDON
MANILLAR

RUOTE
WHEELS
ROUES
RUEDAS

GOMME
TYRES
PNEUS
PNEUMATICOS

REGGISELLA
SEAT POST
TIGE DE SELLE
TIJA

TO6307-L
7v. Lady

Trekking 28" Alloy

Hi ten

Shimano TY-300 /
Ty-21

Shimano Revo

42x170

Shimano TZ500 /
Index 7v.

V-brake Alloy

Alloy / Alloy regolabile
/ Adjustable Alloy

Alloy 28" nero
rettificato / alloy
black rectified 28"

700x38

Alloy

BIVIO MAN

TO6407-M / 7v. Man

SIZE 520

COLORS

NERO C009

BLU C006



PESO
WEIGHT
POIDS
PESO

15,5 kg

TELAJO
FRAME
CADRE
CUADRO

FORCELLA
FORK
FOURCHE
HORQUILLA

CAMBIO
GEARS
ARRIER DER.
CAMBIO POST.

COMANDI
CONTROLS
MANETTES.
PALANCAS DE
CAMBIO

GUARN.
CRANKSET
PEDALIER
BIELA

CASSETTA
CASSETTE
CASSETTE
CASSETTE

FRENI
BRAKES
FREINS
FRENOS

MANUBRIO
HANDLEBAR
GUIDON
MANILLAR

RUOTE
WHEELS
ROUES
RUEDAS

GOMME
TYRES
PNEUS
PNEUMATICOS

REGGISSELLA
SEAT POST
TIGE DE SELLE
TIJA

TO6407-M
7v. Man

Trekking 28" Hi ten Hi ten

Shimano TY-21

Shimano Revo

42x170

Shimano TZ500
/ Index 7v.

V-brake Alloy

Alloy / Alloy regolabile
/ Adjustable Alloy

Alloy silver 28"

700x35

Hi ten

BIVIO LADY

TO6407-L / 7v. Lady

SIZE 460

COLORS

VERDE C013

NERO C009



PESO
WEIGHT
POIDS
PESO

15,5 kg

TELAJO
FRAME
CADRE
CUADRO

FORCELLA
FORK
FOURCHE
HORQUILLA

CAMBIO
GEARS
ARRIER DER.
CAMBIO POST.

COMANDI
CONTROLS
MANETTES.
PALANCAS DE
CAMBIO

GUARN.
CRANKSET
PEDALIER
BIELA

CASSETTA
CASSETTE
CASSETTE
CASSETTE

FRENI
BRAKES
FREINS
FRENOS

MANUBRIO
HANDLEBAR
GUIDON
MANILLAR

RUOTE
WHEELS
ROUES
RUEDAS

GOMME
TYRES
PNEUS
PNEUMATICOS

REGGISSELLA
SEAT POST
TIGE DE SELLE
TIJA

TO6407-L
7v. Lady

Trekking 28" Hi ten

Hi ten

Shimano TY-21

Shimano Revo

42x170

Shimano TZ500
/ Index 7v.

V-brake Alloy

Alloy / Alloy regolabile
/ Adjustable Alloy

Alloy silver 28"

700x35

Hi ten

ANITA 28"

TO6507 / 28" 7V.

SIZE 460

COLORS

BIANCO C003

GRIGIO C004

PESO
WEIGHT
POIDS
PESO

14,8 kg



TELAIO
FRAME
CADRE
CUADRO

FORCELLA
FORK
FOURCHE
HORQUILLA

CAMBIO
GEARS
ARRIER DER.
CAMBIO POST.

COMANDI
CONTROLS
MANETTES.
PALANCAS DE
CAMBIO

GUARN.
CRANKSET
PEDALIER
BIELA

CASSETTA
CASSETTE
CASSETTE
CASSETTE

FRENI
BRAKES
FREINS
FRENOS

MANUBRIO
HANDLEBAR
GUIDON
MANILLAR

RUOTE
WHEELS
ROUES
RUEDAS

GOMME
TYRES
PNEUS
PNEUMATICOS

REGGISSELLA
SEAT POST
TIGE DE SELLE
TIJA

TO6507
28" 7V.

Monotrave 28"
Alloy

Hi ten

Shimano TY-300
/ Ty-21

Shimano Revo

42x170

Shimano TZ500 /
Index 7v.

V-brake Alloy

Hi ten / Alloy regolabile
/ Adjustable Alloy

Alloy 28"

700x35

Hi ten

ANITA 26"

TO6607 / 26" 7V.

SIZE 430

COLORS

BIANCO C003

GRIGIO C004

PESO
WEIGHT
POIDS
PESO

15 kg



TELAIO
FRAME
CADRE
CUADRO

FORCELLA
FORK
FOURCHE
HORQUILLA

CAMBIO
GEARS
ARRIER DER.
CAMBIO POST.

COMANDI
CONTROLS
MANETTES.
PALANCIAS DE
CAMBIO

GUARN.
CRANKSET
PEDALIER
BIELA

CASSETTA
CASSETTE
CASSETTE
CASSETTE

FRENI
BRAKES
FREINS
FRENOS

MANUBRIO
HANDLEBAR
GUIDON
MANILLAR

RUOTE
WHEELS
ROUES
RUEDAS

GOMME
TYRES
PNEUS
PNEUMATI-
COS

REGGISSELLA
SEAT POST
TIGE DE SELLE
TIJA

TO6607
26" 7V.

Monotrave 26"
Alloy

Hi ten

Shimano TY-300
/ Ty-21

Shimano Revo

42x170

Shimano TZ500 /
Index 7v.

V-brake Alloy

Hi ten / Alloy regolabile
/ Adjustable Alloy

Alloy 26"

26x1.75

Hi ten

ALYA 24"

TO6706 / 6v. Revo

SIZE 350

COLORS

BIANCO C003

MAGENTA C002

PESO
WEIGHT
POIDS
PESO

14,7 kg



TELAIO
FRAME
CADRE
CUADRO

FORCELLA
FORK
FOURCHE
HORQUILLA

CAMBIO
GEARS
ARRIER DER.
CAMBIO POST.

COMANDI
CONTROLS
MANETTES.
PALANCAS DE
CAMBIO

GUARN.
CRANKSET
PEDALIER
BIELA

CASSETTA
CASSETTE
CASSETTE
CASSETTE

FRENI
BRAKES
FREINS
FRENOS

MANUBRIO
HANDLEBAR
GUIDON
MANILLAR

RUOTE
WHEELS
ROUES
RUEDAS

GOMME
TYRES
PNEUS
PNEUMATICOS

REGGISELLA
SEAT POST
TIGE DE SELLE
TIJA

TO6706
24" 6V. REVO

Hi Ten Tig

Hi Ten Tig

Shimano Ty-21

Shimano Revo

36T

Shimano TZ500 /
Index 6v.

V-brake Alloy

Hi ten

Alloy

24x1.75

Hi Ten

ALYA 20"

TO6806 / 6v. Revo

SIZE 300

COLORS

BIANCO C003

MAGENTA C002

PESO
WEIGHT
POIDS
PESO

12,5 kg



TELAIO
FRAME
CADRE
CUADRO

FORCELLA
FORK
FOURCHE
HORQUILLA

CAMBIO
GEARS
ARRIER DER.
CAMBIO POST.

COMANDI
CONTROLS
MANETTES.
PALANCAS DE
CAMBIO

GUARN.
CRANKSET
PEDALIER
BIELA

CASSETTA
CASSETTE
CASSETTE
CASSETTE

FRENI
BRAKES
FREINS
FRENOS

MANUBRIO
HANDLEBAR
GUIDON
MANILLAR

RUOTE
WHEELS
ROUES
RUEDAS

GOMME
TYRES
PNEUS
PNEUMATICOS

REGGISELLA
SEAT POST
TIGE DE SELLE
TIJA

TO6806
20" 6V. REVO

Hi Ten Tig

Hi Ten Tig

Shimano Ty-21

Shimano Revo

36T

Shimano TZ500 /
Index 6v.

V-brake Alloy

Hi ten

Alloy

20x1.75

Hi Ten

POPZ 16"

TO7500-M / 16"



COLORS

BLU C006

ROSSO C007

POPZ 12"

TO7400-M / 12"



TELAIO
FRAME
CADRE
CUADRO

FORCELLA
FORK
FOURCHE
HORQUILLA

GUARN.
CRANKSET
PEDALIER
BIELA

FRENI
BRAKES
FREINS
FRENOS

MANUBRIO
HANDLEBAR
GUIDON
MANILLAR

RUOTE
WHEELS
ROUES
RUEDAS

GOMME
TYRES
PNEUS
PNEUMATICOS

REGGISELLA
SEAT POST
TIGE DE SELLE
TIJA

TO7500-M

Hi ten 16"

Hi ten

32x127

V-brake Alloy

Hi ten

Alloy 16"

16x1.75

Hi ten

TO7400-M

Hi ten 12"

Hi ten

28x90

V-brake Alloy

Hi ten

Alloy 12"

12x1.75

Hi ten

FLOR 16"

TO7500-L / 16"



COLORS

BIANCO C003

MAGENTA C002

FLOR 12"

TO7400-L / 12"



TELAIO
FRAME
CADRE
CUADRO

FORCELLA
FORK
FOURCHE
HORQUILLA

GUARN.
CRANKSET
PEDALIER
BIELA

FRENI
BRAKES
FREINS
FRENOS

MANUBRIO
HANDLEBAR
GUIDON
MANILLAR

RUOTE
WHEELS
ROUES
RUEDAS

GOMME
TYRES
PNEUS
PNEUMATICOS

REGGISELLA
SEAT POST
TIGE DE SELLE
TIJA

TO7500-L

Hi ten 16"

Hi ten

32x127

V-brake Alloy

Hi ten

Alloy 16"

16x1.75

Hi ten

TO7400-L

Hi ten 12"

Hi ten

28x90

V-brake Alloy

Hi ten

Alloy 12"

12x1.75

Hi ten

DARSENA LADY

TO8207-L / Ty-300 7v.

SIZE 460

COLORS

BIANCO-MARRONE C038

GRIGIO C004

PESO
WEIGHT
POIDS
PESO

16 kg



TELAJO
FRAME
CADRE
CUADRO

FORCELLA
FORK
FOURCHE
HORQUILLA

CAMBIO
GEARS
ARRIER DER.
CAMBIO POST.

COMANDI
CONTROLS
MANETTES.
PALANCAS DE
CAMBIO

GUARN.
CRANKSET
PEDALIER
BIELA

CASSETTA
CASSETTE
CASSETTE
CASSETTE

FRENI
BRAKES
FREINS
FRENOS

MANUBRIO
HANDLEBAR
GUIDON
MANILLAR

RUOTE
WHEELS
ROUES
RUEDAS

GOMME
TYRES
PNEUS
PNEUMATICOS

REGGISELLA
SEAT POST
TIGE DE SELLE
TIJA

TO8207-L
Ty-300 7v.

Alloy City 26"

Hi ten

Shimano TY-300
/ Ty-21

Shimano Revo

Alloy 42x170

Shimano TZ500 /
Index 7v.

V-brake Alloy

Alloy

Alloy 26" doppia
camera / Dual
chamber

26x2.25

Alloy

DARSENA LADY

TO8207-L / Ty-300 7v.

SIZE 460

PESO
WEIGHT
POIDS
PESO

16 kg



DARSENA MAN

TO8207-M / Ty-300 7v.

SIZE 500-550

PESO
WEIGHT
POIDS
PESO

16 kg

COLORS

GRIGIO C004



TELAJO
FRAME
CADRE
CUADRO

FORCELLA
FORK
FOURCHE
HORQUILLA

CAMBIO
GEARS
ARRIER DER.
CAMBIO POST.

COMANDI
CONTROLS
MANETTES.
PALANCAS DE
CAMBIO

GUARN.
CRANKSET
PEDALIER
BIELA

CASSETTA
CASSETTE
CASSETTE
CASSETTE

FRENI
BRAKES
FREINS
FRENOS

MANUBRIO
HANDLEBAR
GUIDON
MANILLAR

RUOTE
WHEELS
ROUES
RUEDAS

GOMME
TYRES
PNEUS
PNEUMATICOS

REGGISSELLA
SEAT POST
TIGE DE SELLE
TIJA

TO8207-M
Ty-300 7v.

Alloy City 26"

Hi ten

Shimano TY-300
/ Ty-21

Shimano Revo

Alloy 42x170

Shimano TZ500 /
Index 7v.

V-brake Alloy

Alloy

Alloy 26" doppia
camera / Dual
chamber

26x2.25

Alloy

CENTRO

TO8106 / Pieghevole 20" 6v.

COLORS

BIANCO C003

NERO C009



PESO
WEIGHT
POIDS
PESO

13,4 kg

TELAIO
FRAME
CADRE
CUADRO

FORCELLA
FORK
FOURCHE
HORQUILLA

CAMBIO
GEARS
ARRIER DER.
CAMBIO POST.

COMANDI
CONTROLS
MANETTES.
PALANCAS DE
CAMBIO

GUARN.
CRANKSET
PEDALIER
BIELA

CASSETTA
CASSETTE
CASSETTE
CASSETTE

FRENI
BRAKES
FREINS
FRENOS

MANUBRIO
HANDLEBAR
GUIDON
MANILLAR

RUOTE
WHEELS
ROUES
RUEDAS

GOMME
TYRES
PNEUS
PNEUMATICOS

REGGISSELLA
SEAT POST
TIGE DE SELLE
TIJA

TO8106
Pieghevole
20" 6v.

Folding 20" alloy

Hi ten

Shimano TY-21

Shimano Revo

Alloy 42x170

Shimano TZ500 /
Index 6v.

V-brake Alloy

Alloy pieghevole
/ folding

Alloy 20"

20x1.75

Alloy

SPORT MAN

TO6700-M / 1v.

COLORS

NERO C009

GRIGIO C004



PESO
WEIGHT
POIDS
PESO

15,5 kg

TELAIO
FRAME
CADRE
CUADRO

FORCELLA
FORK
FOURCHE
HORQUILLA

GUARN.
CRANKSET
PEDALIER
BIELA

FRENI
BRAKES
FREINS
FRENOS

MANUBRIO
HANDLEBAR
GUIDON
MANILLAR

RUOTE
WHEELS
ROUES
RUEDAS

GOMME
TYRES
PNEUS
PNEUMATICOS

REGGISELLA
SEAT POST
TIGE DE SELLE
TUA

TO6700-M
1v.

Hi Ten Tig

Hi Ten Tig

42T

V-brake Alloy

Hi ten

Alloy

700x35

Hi Ten

SPORT LADY

TO6700-L / 1v.

COLORS

NERO C009

PANNA C001



PESO
WEIGHT
POIDS
PESO

15,5 kg

TELAIO
FRAME
CADRE
CUADRO

FORCELLA
FORK
FOURCHE
HORQUILLA

GUARN.
CRANKSET
PEDALIER
BIELA

FRENI
BRAKES
FREINS
FRENOS

MANUBRIO
HANDLEBAR
GUIDON
MANILLAR

RUOTE
WHEELS
ROUES
RUEDAS

GOMME
TYRES
PNEUS
PNEUMATICOS

REGGISELLA
SEAT POST
TIGE DE SELLE
TIJA

TO6700-L
1v.

Hi Ten Tig

Hi Ten Tig

42T

V-brake Alloy

Hi ten

Alloy

26"x1 3/8

Hi Ten

APPAREL

IT. Completi racing dall'inconfondibile design italiano, sia per la stagione estiva che invernale, realizzati in due varianti cromatiche con tessuti e soluzioni tecniche innovative che regalano comfort, protezione e leggerezza per una migliore prestazione sportiva.

EN. Racing outfits with an unmistakable Italian design, for both summer and winter, made in two colors with innovative fabrics and technical solutions that offer comfort, protection and lightness for better sports performance.

FR. Complets racing à l'incomparable design italien, aussi bien pour l'été que pour l'hiver, réalisés en deux variantes chromatiques avec des tissus et des solutions techniques innovants offrant confort, protection et légèreté pour une meilleure prestation sportive.

ES. Conjuntos racing de inconfundible diseño italiano, tanto para la temporada de verano como de invierno, en dos variantes de color, con tejidos y soluciones técnicas innovadoras que brindan confort, protección y ligereza para mejorar las prestaciones deportivas.

CORSA NERO

TO0001 / C009 1



TO0003 / C009 3



2 TO0002 / C009

4 TO0004 / C009

5 TO0011 / C009



6 TO0012 / C009



7 TO0005 / C009



1- Maglia manica corta con fronte e retro in tessuto THINK, collo, fianchi e maniche in tessuto ROMBO®. 3 tasche posteriori applicate, elastico a vista bianco a fine manica ed elastico interno con silicone sul fondo. / Short-sleeved jersey with front and back in THINK fabric, collar, sides and sleeves in ROMBO® fabric. 3 back patch pockets, white elastic band at the end of the sleeve and inner elastic with silicone on the bottom. / Tricot manche courte avec devant et dos en tissu THINK, col, côtés et manches en tissu ROMBO®. 3 poches arrière appliquées, élastique apparent blanc en bas de manche et élastique interne avec du silicone en bas du tricot. / Camiseta de manga corta con parte delantera y trasera en tejido THINK, cuello, flancos y mangas en tejido ROMBO®. 3 bolsillos traseros aplicados, elástico visto blanco en el borde de la manga y elástico interno con silicona en el borde inferior.

2- Salopette con calzoncino in tessuto ROMBO®, elastico a vista bianco, fondello in gel Bormio e ricamo Olmo su fondo gamba. / Bib shorts in ROMBO® fabric, white elastic band, Bormio gel chamois and Olmo embroidery at the bottom of the leg. / Salopette avec short en tissu ROMBO®, élastique apparent blanc, entrejambe en gel Bormio et broderie Olmo sur le bas de la jambe. / Mono con calzón en tejido ROMBO®, elástico visto blanco, almohadillado en gel Bormio y bordado Olmo en el borde de la pernera.

3- Maglia termofelpata a manica lunga, in tessuto garzato con zip lunga, 3 tasche posteriori applicate e bordino in lycra a fine manica. / Long-sleeved insulated jersey in brushed fabric with long zipper, 3 back patch pockets and Lycra edging at the end of the sleeve. / Tricot thermo-molletonné à manche longue, en tissu gratté, zip longue, 3 poches arrière appliquées et bord en lycra en bas de manche. / Camiseta térmica afelpada de manga larga, en tejido cardado con cremallera larga, 3 bolsillos traseros aplicados y borde de lycra en los puños.

4- Salopette con calzamaglia in tessuto SUPER ROUBAIX®, elastico a vista, fondello in gel Bormio e ricamo Olmo sulla coscia. / Bib tights in SUPER ROUBAIX® fabric, exposed elastic, Bormio gel chamois and Olmo embroidery on the thigh. / Salopette avec collant en tissu SUPER ROUBAIX®, élastique apparent, entrejambe en gel Bormio et broderie Olmo sur la cuisse. / Mono con leotardo en tejido SUPER ROUBAIX®, elástico visto, almohadillado en gel Bormio y bordado Olmo en el muslo.

5- Giubbino smanicato con fronte antivento EVENT® leggero e retro in RAPID DRY®. Bordino in lycra giro manica. / Vest with light EVENT® windbreaker front and RAPID DRY® back. Lycra sleeve edging. / Gilet sans manches avec partie frontale anti-vent EVENT® léger et rétro en RAPID DRY®. Bord en lycra à l'épaule. / Chaleco con pechera de protección contra el viento EVENT® ligero y retro RAPID DRY®. Borde de lycra en las sisas.

6- Giubbino invernale in tessuto EVENT® pesante con bordino in Lycra a fine manica, zip anteriore lunga e zip posteriori catarifrangenti. / Winter jacket in heavy EVENT® fabric with Lycra edging at the end of the sleeve, long front zipper and reflective rear zipper. / Gilet d'hiver en tissu EVENT® traversant, avec bord en Lycra en bas de manche, zip avant longue et zip arrière réfléchissantes. / Chaqueta de invierno en tejido EVENT® grueso con borde de lycra en los puños, cremallera delantera larga y cremalleras traseras reflectantes.

7- Casco protettivo in EPS+PC con struttura a conchiglia composita a 3 strati per una maggiore protezione e capacità di assorbimento degli urti. Certificazione CE EN1078. / Protective helmet in EPS+PC with a 3-layer composite shell structure for added protection and shock absorption. CE EN1078 certification. / Casque de protection en EPS+PC avec structure en coquille composite à 3 couches pour une meilleure protection et capacité d'absorption des chocs. Certification CE EN1078. / Casco de protección en EPS+PC con estructura de la concha compuesta de 3 capas para una mayor protección y capacidad de absorción de los golpes. Certificación CE EN1078.

CORSA BLU

TO0001 / C006 1

TO0003 / C006 3



2 TO0002 / C006

4 TO0004 / C006



5 TO0011 / C006

6 TO0012 / C006

7 TO0005 / C006

GARANZIA

GARANZIA

Montana S.r.l. garantisce il telaio per il periodo di due anni (12 mesi per la verniciatura e cromatura) mentre per tutte le componenti vale la garanzia della casa produttrice. La garanzia ha inizio dalla data di acquisto, purché tale acquisto sia avvenuto presso un rivenditore autorizzato. In caso di difetti di fabbricazione o imputabili ai materiali impiegati e purché il telaio sia sottoposto alle normali condizioni d'uso, Montana S.r.l. si impegna a riparare o sostituire le parti in garanzia risultate difettose, mentre saranno a carico del cliente le spese di trasporto. Ferme restando le caratteristiche essenziali, ci riserviamo il diritto di eventuali variazioni tecniche o di accessori per qualunque modello illustrato in catalogo. I colori delle biciclette presenti su questo catalogo possono avere variazioni essendo stampati su materiali diversi. Le immagini contenute nel catalogo sono puramente indicative: Montana S.r.l. si riserva il diritto di apportare eventuali modifiche atte a migliorare la qualità dei prodotti illustrati senza alcun preavviso. Per quanto riguarda le e-bikes, la garanzia su motori e batterie è di 2 anni, tranne nel caso di noleggi dove viene ridotta a 1 anno sul motore e 1 anno sulla batteria con capacità minima del 70% e 500 cicli.

WARRANTY

Montana S.r.l. guarantees the frame for a period of two years (12 months for paint and chrome plating); for all components, the manufacturer's warranty shall apply. The warranty begins from the date of purchase, provided that the purchase took place at an authorized dealer. In case of manufacturing defects or defects attributable to the materials used and provided that the frame is subjected to normal usage conditions, Montana S.r.l. shall repair or replace the parts under warranty found to be defective. Shipping costs will be charged to the customer. Without prejudice to the essential specifications, we reserve the right to make any technical changes or changes in accessories for any model shown in the catalog. The colors of the bicycles in this catalog may present variations due to their being printed on different materials. The images contained in the catalog are purely for illustration purposes: Montana S.r.l. reserves the right to make any changes to improve the quality of the products illustrated without prior notice. Concerning e-bikes, the warranty for both motor and battery is 2 years; if the bike is a rental model, the warranty is 1 year on the motor and 1 year on the battery with a minimum capacity of 70% or 500 recharge cycles.

GARANTIE

Montana S.r.l. garantit le cadre pour une période de deux ans (12 mois pour la peinture et le chromage), tandis que tous les composants relèvent de la garantie du fabricant. La garantie prend effet à compter de la date d'achat, à condition que l'article ait été acheté chez un revendeur autorisé. En cas de défauts de fabrication ou imputables aux matériaux employés, et à condition que le cadre soit soumis à des conditions normales d'utilisation, Montana S.r.l. s'engage à réparer ou remplacer les parties en garantie qui s'avèreraient défectueuses, tandis que les frais de transport seront à la charge du client. Sans préjudice des caractéristiques essentielles, nous nous réservons le droit d'appliquer des variations techniques ou d'accessoires éventuelles pour tout modèle illustré dans le catalogue. Les couleurs des vélos présents sur ce catalogue peuvent subir des variations, étant donné qu'ils sont appliqués sur des matériaux divers. Les images contenues dans le catalogue sont purement indicatives: Montana S.r.l. se réserve le droit d'apporter, sans aucun préavis, d'éventuelles modifications propres à améliorer la qualité des produits illustrés. Pour les E-Bikes la garantie sur moteur et batterie est de 2 ans, réduite à 1 an en cas de vélos utilisés en location (dans ce cas pour la batterie capacité minimale de 70% et 500 cycles).

GARANTÍA

Montana S.r.l. garantiza el chasis durante un período de dos años (12 meses para la pintura y el cromado), mientras que para todos los componentes es válida la garantía del fabricante. La garantía entra en vigor en el momento de la compra, siempre que dicha compra se haya efectuado en un establecimiento autorizado. En caso de defectos de fabricación o imputables a los materiales empleados, y siempre que el chasis sea sometido a las condiciones de uso normales, Montana S.r.l. se compromete a reparar o cambiar las piezas en garantía que resulten defectuosas, mientras que los gastos de transporte correrán a cargo del cliente. Sin perjuicio de las características esenciales, nos reservamos el derecho a posibles variaciones técnicas o de accesorios para cualquier modelo ilustrado en el catálogo. Los colores de las bicicletas incluidas en este catálogo pueden sufrir variaciones, al estar impresos en materiales diferentes. Las imágenes contenidas en el catálogo son meramente indicativas. Montana S.r.l. se reserva el derecho de aportar posibles cambios destinados a mejorar la calidad de los productos ilustrados sin previo aviso. En cuanto a las bicicletas eléctricas, la garantía de los motores y las baterías son de 2 años, excepto en el caso de alquileres donde se reduce a 1 año en el motor y 1 año en la batería con una capacidad mínima de 70% y 500 ciclos.

MONTANA S.R.L.

Via Domenico Rossi 70,
12060 Magliano Alpi (CN) - Italy
Tel. +39 017466828 / Fax +39 017466651
olmo@olmo-bike.it - **www.olmo-bike.it**